



 KUNDALINI

 **KUNDALINI**

CATALOGUE / 2011

VISION

*... besides being designed, light in turn designs
our perception of the world and of life itself ...*

Kundalini starts its activity back in 1996, when it developed the intuition of a new typology of lamps, extremely innovative and outrageous forms of light, symptomatic of a strong identity and a product culture expression of a universal language.

Since Kundalini has been considerably successful, to the point of being in Italy and abroad one of the most published company in its field. But the great visibility of Kundalini in the media has gone well beyond the strictly professional area of design specialists, since its products have frequently appeared in international movie productions, advertisements, television programmes and video-clips. Historic products such as the floor lamp E.T.A., the Shakti collection, Bokka and recently Kyudo have already become cult icons for the media worldwide.

Kundalini has been classified by the international contemporary design community as a pioneering company not only for the development of the new themes that it has introduced and which are now very widespread, but also for the innovative spirit of its style and the advanced research work in new production technologies and the new materials.

It's now a company with extensive experience, which is still oriented towards the identification of cutting-edge research solutions always original and highly creative, that each time draws inspiration from different worlds. From nature, industrial landscapes or the visual arts. In what is always a perfectly calibrated synthesis of function and emotion.

Kundalini counts on the cooperation of emerging talents, internationally renowned designers and architects who are sharing and underlining the company mission.

*... la luce non solo è disegnata, ma a sua volta
disegna la nostra percezione del mondo e della vita ...*

Kundalini inizia la propria attività nel 1996, con l'intuizione di una nuova tipologia di lampade, forme di luce estremamente innovative e altrettanto coraggiose, sintomatiche di un'identità forte e una cultura del prodotto espressione di un linguaggio universale.

Il riconoscimento che l'azienda ha avuto sin dagli esordi è senza precedenti, ponendola in Italia e a livello internazionale, fra le aziende più pubblicate del proprio settore. Ma la forte esposizione mediatica di Kundalini è andata ben oltre il raggio di ricezione dell'area degli specialisti di Design, contando numerose apparizioni dei propri prodotti in produzioni cinematografiche, pubblicitarie, televisive e di videoclip internazionali. Prodotti storici come la lampada da terra E.T.A., la collezione Shakti, Bokka e più recentemente Kyudo sono già icone cult dei media di tutto il mondo. Kundalini è stata accreditata nell'ambito internazionale del design contemporaneo come un'azienda pionieristica non solo nello sviluppo delle tematiche che ha introdotto, ma soprattutto per lo spirito innovativo che contraddistingue il suo stile e la ricerca avanzata nell'ambito delle nuove tecnologie produttive e dei nuovi materiali.

E' oggi un'azienda con una solida esperienza, instancabilmente orientata all'individuazione di traiettorie di ricerca d'avanguardia sempre inedite e ad alto tasso creativo, ispirate di volta in volta da mondi diversi. La natura, gli scenari industriali, le arti visive. Il tutto in una sintesi sempre perfettamente calibrata tra funzione ed emozione.

Kundalini si avvale della collaborazione di talenti emergenti, designer e architetti di fama internazionale che ne condividono e sottolineano la mission.

... Licht wird nicht nur entworfen,

Licht entwirft wiederum die Welt und das Leben so wie wir beides wahrnehmen...

Kundalini beginnt die Tätigkeit 1996 mit der Idee einer neuen Typologie von Lampen, extrem innovativ und mit aufregenden Formen der Lichtkreationen, hoher Identität und Produktkultur und mit dem Ausdruck einer universellen Formensprache.

Dank der großen Anerkennung die das Unternehmen seit seinem Beginn erhalten hat, gehört Kundalini in Italien sowie auf internationaler Ebene zu den meist gefragten dieser Branche. Jedoch hat die starke Medienpräsenz von Kundalini das Ziel der Design-Spezialisten bei weitem überholt, und Kundalini-Objekte sind in zahlreichen Filmproduktionen, Werbespots, TV-Produktionen und internationalen Videoclips erschienen. Historische Produkte wie die Bodenleuchte E.T.A., die Modelle der Reihe Shakti, Bokka und die jüngsten Kyudo zählen schon jetzt zu den Kult-Ikonen der Medien weltweit. Kundalini ist im Bereich zeitgenössisches Design auf internationaler Ebene als Pionierunternehmen anerkannt worden, nicht nur die Entwicklung der von ihm eingeführten Themen betreffend, sondern vor allem seines innovativen Geistes wegen, der seinen unnachahmlichen Stil hervorhebt, der Suche nach neuen Produktionstechnologien, neuen Materialien.

Kundalini ist heute ein Unternehmen mit solider Erfahrung, unermüdlich auf der Suche nach neuen avantgardistischen Forschungstrends, immer originell und kreativ arbeitend, inspiriert durch die Natur, die industrialisierten Landschaften oder die Kunst. Und das zeigt sich in unseren Produkten, eine wunderbare Synthese aus Funktion und Emotion.

Kundalini kann sich der Zusammenarbeit mit namhaften internationalen Designern und Architekten rühmen, die dieses Ziel unterstützen und in den Vordergrund heben.

... la lumière non seulement est dessinée, mais

dessine à son tour notre perception du monde et de la vie...

Kundalini commence son activité en 1996, avec l'intuition d'une nouvelle typologie de lampes des formes extrêmement innovantes et scandaleuse de la lumière, symptomatique d'une forte identité et une culture du produit qui devient l'expression d'un langage universel.

La reconnaissance sans égal que Kundalini a eue dès ses débuts l'a placé parmi les entreprises les plus publiées dans son secteur, aussi bien en Italie qu'à l'international. Mais la grande exposition médiatique de Kundalini est allée bien au-delà de l'univers des spécialistes du Design, avec de nombreuses apparitions de ses produits dans des productions cinématographiques, publicitaires, télévisées et de clips vidéo internationaux.

Des produits historiques comme le lampadaire E.T.A., la collection Shakti, Bokka et plus récemment Kyudo sont déjà des icônes cultes des médias du monde entier.

Kundalini a été accréditée dans le milieu international du Design contemporain comme une entreprise pionnière non seulement dans le développement des thèmes introduits, mais surtout pour l'esprit innovant caractérisant son style et la recherche avancée dans les nouvelles technologies de production, des nouveaux matériaux.

Aujourd'hui Kundalini est une entreprise qui peut compter sur une expérience solide, sans cesse orientée à l'identification de trajectoires d'étude d'avant-garde toujours original et très créatif, qui puise à chaque fois son inspiration dans des mondes différents. De nature, les paysages industriels ou les arts visuels.

Sont toujours une synthèse parfaitement calibré de la fonction et l'émotion.

Kundalini collabore avec des talents, designers et architectes de renommée internationale qui en partagent et mettent en exergue la mission.

... la luz no está sólo diseñada,

sino que a su vez diseña nuestra percepción del mundo y de la vida...

Kundalini inicia su actividad en 1996, con la intuición de una nueva tipología de lámparas, formas de luz extremadamente innovadoras, sintomáticas de una fuerte identidad y una cultura del producto que se convierte en la expresión de un idioma universal.

El reconocimiento que Kundalini ha tenido desde sus inicios es sin precedentes y la coloca en Italia y a nivel internacional entre las empresas más publicadas de su sector. Pero la gran exposición mediática de Kundalini ha ido mucho más allá del radio de recepción del área de los especialistas de Diseño, contando con numerosas apariciones de sus propios productos en producciones cinematográficas, publicitarias, televisivas y de videoclips internacionales.

Productos históricos como la lámpara de pie E.T.A., la colección Shakti, Bokka y más recientemente Kyudo ya son iconos cult de los medios de todo el mundo. Kundalini ha sido acreditada en el ámbito internacional del Diseño contemporáneo como una empresa pionera, no sólo en el desarrollo de los temas que ha introducido, sino sobre todo por el espíritu innovador que caracteriza su estilo y la investigación avanzada en el ámbito de las nuevas tecnologías productivas, de los nuevos materiales.

Kundalini es hoy una empresa con una sólida experiencia, incesantemente orientada a la identificación de líneas de investigación de vanguardia siempre original y altamente creativa, inspirada cada vez en mundos diversos. La naturaleza, los escenarios industriales, o las artes visuales. El todo en una síntesis siempre perfectamente calibrada entre la función y la emoción.

Cuenta con la valiosa colaboración de talentos, diseñadores y arquitectos de fama internacional que comparten y destacan la misión de la empresa.

DESIGNERS



1. Norman Foster / 2. Patrick Norguet / 3. Future Systems / 4. Karim Rashid / 5. Jean Marie Massaud / 6. Patricia Urquiola / 7. Alessandro Mendini / 8. Benjamin Hopf Constantin Wortmann / 9. Arik Levy / 10. Benjamin Hubert / 11. AquilAberg / 12. Christophe Pillet / 13. Ludovica&Roberto Palomba / 14. Paola Navone / 15. Emmanuel Babled / 16. Lionel Dean / 17. Helen Kontouris / 18. Osko+Deichmann / 19. Giorgio Gurioli / 20. Brodie Neill / 21. Paolo Cazzaro / 22. Bakery Group / 23. A+A Cooren / 24. Hansandfranz / 25. De-Signum / 26. Gregorio Spini / 27. Guglielmo Berchicci / 28. Marzio Rusconi Clerici Laura Agnoletto / 29. John Sebastian / 30. Patrizio Orlandi / 31. Marco Valente / 32. Juanico

INDEX

/ floor /



Asana
/ 76



E.T.A.
/ 80

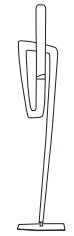

Homology
/ 36



Luminal
/ 52



Spillo / floor
/ 24



Tripod / floor
/ 60

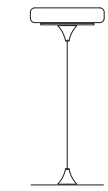

Eero / floor
/ 48



Floob
/ 44

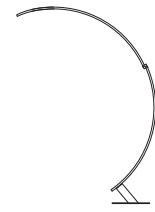

Kyudo
/ 20

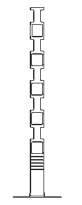

Sama
/ 72



Spillo / outdoor
/ 28

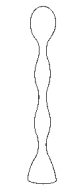

Yoga
/ 84



Evita
/ 16



Gina / floor
/ 40



La La Lamp
/ 56



Shakti
/ 64



Tonic / floor
/ 68

/ table /



Abyss
/ 104



Bokka
/ 120



E.T.A. Baby
/ 146

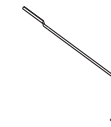

Linea1
/ 100

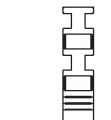

Sama / table
/ 134

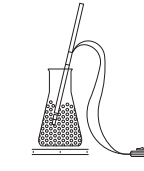

Alchemy
/ 142



Candela
/ 124



Gherkin
/ 116



Mirage
/ 150



Tonic / table
/ 130

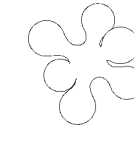

Atomium
/ 88



Eero / table
/ 138

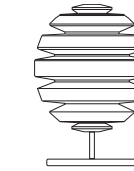

Honeymoon / table
/ 108



Noglobe / table
/ 128



Tripod / table
/ 154

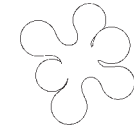

Atomium / outdoor
/ 92



Entropia
/ 112

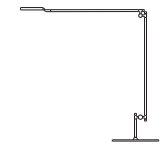

Linea
/ 96

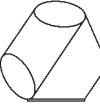

Padma / table
/ 144

/ suspension /

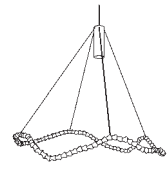

Abyss / ceiling
/ 176

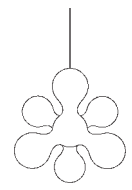

Atomium / ceiling
/ 180



Bokka / ceiling
/ 202

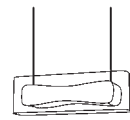

Bolido
/ 184

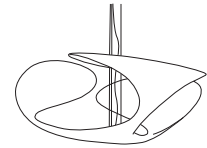

Clover
/ 156

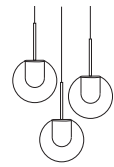

Dew
/ 168



Entropia / ceiling
/ 196

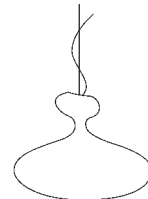

E.T.A. Sat
/ 230



Drop
/ 264



Evita / wall
/ 242

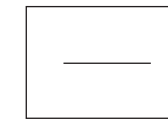

Flap
/ 278

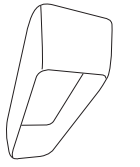

Frame
/ 238

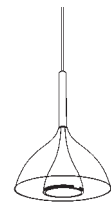

Floob / ceiling
/ 204

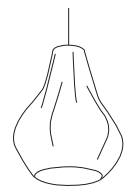

Gina / ceiling
/ 172

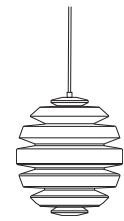

Honeymoon / ceiling
/ 188

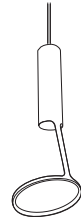

Loup-o
/ 192

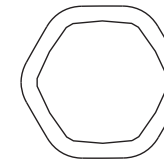

Hexagon
/ 258

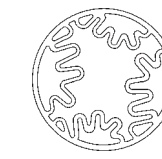

Mandala Mendini
/ 282

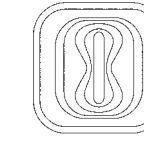

Mandala Rashid
/ 286

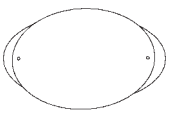

Morphie
/ 270

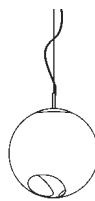

Noglobe / ceiling
/ 212

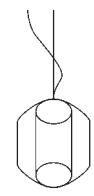

Padma / ceiling
/ 226

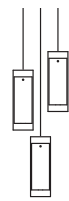

Pipe
/ 222

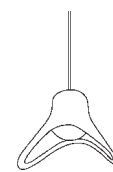

Pluto / ceiling
/ 198



Pastilla
/ 290

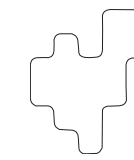

Pixel
/ 246

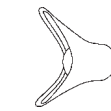

Pluto / wall
/ 294

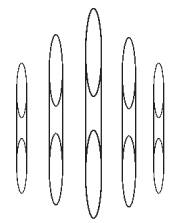

Shakti / wall
/ 274



Sama / ceiling
/ 220

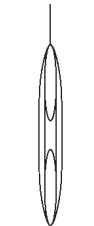

Shakti Air
/ 206



Shakti Sky
/ 208



Spillo / ceiling
/ 164

/ furnishing /

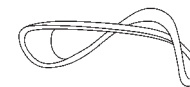

E-Turn
/ 296

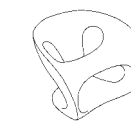

Hara
/ 300

CONTENTS

Floor / 16
Table / 88
Ceiling / 156
Wall / 238
Furnishing / 296

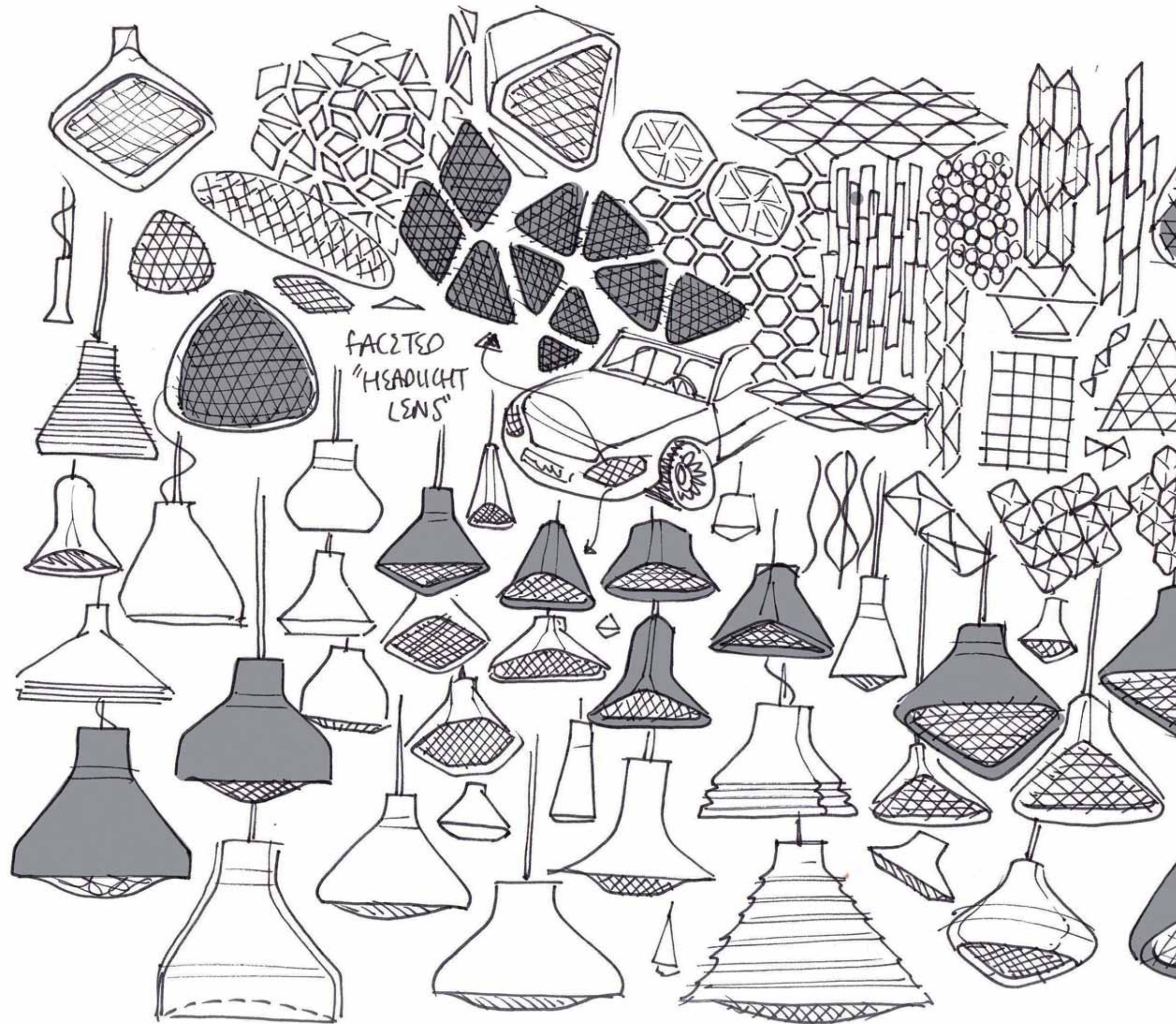

EVITA
AQUILIALBERG / 2011



EVITA

AQUILIALBERG / 2011

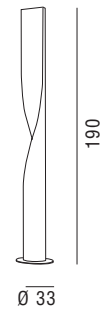

Dimmable floor lamp. Powder coated laser cut metal structure, opal methacrylate diffuser.

Lampada da terra dimmerabile. Struttura in metallo verniciato tagliato laser, diffusore in metacrilato opalino.

Dimmbare Stehleuchte. Lasergeschnittene lackierte Metallstruktur, Diffusor aus Methacrylat Opalin.

Lampe de terre a variateur. Structure en métal verni coupé laser, diffuseur méthacrylate opalin.

Lámpara de pié dimerable. Estructura en metal lacado corte laser, difusor en metacrilato opal.

certifications / certificazioni

□ C E IP20

bulbs / lampadine

2 x 54W T5 Fluor

feeding / alimentazione

230 / 120 V

dimensions / dimensioni

Ø 33 cm - H 190 cm

finishing / finitura

gloss powder coated
verniciatura a polveri lucida

colours / colori

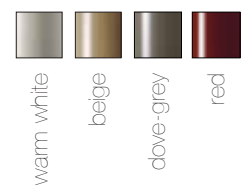

warm white

beige

dove-grey

red



KYUDO
HANSANDFRANZ / 2010



KYUDO

HANSANDFRANZ / 2010

Floor lamp with diffuser mounted on adjustable sliding track. Glossy varnished extruded aluminium structure. Low voltage Led strip.

Lampada da terra con diffusore montato su binario scorrevole regolabile a piacere. Struttura in estruso di alluminio verniciato lucido. Led strip a bassa tensione.

Bodenleuchte, mit einem Diffusor auf einer Gleitschiene montiert und nach Belieben regulierbar. Struktur aus glanzlackiertem Aluminiumdruckguss. Led Leuchtstreifen mit Niederspannung.

Lampadaire avec diffuseur réglable monté sur rail coulissant. Structure en aluminium extrudé avec application de vernis lucide. Led strip basse tension.

Lámpara de pie con difusor montado sobre un riel corredizo, regulable. Estructura en extrudido de aluminio barnizado brillante. Cable de Led de baja tensión.

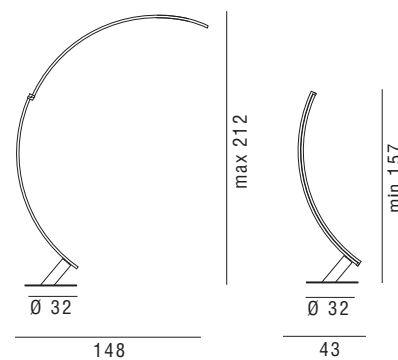

certifications / certificazioni

CE IP20

bulbs / lampadine

2 x 21,6W Led Strip

feeding / alimentazione

230 / 120 V

dimensions / dimensioni

Ø 32 cm - L 43/148 cm - H 157/212 cm

finishing / finitura

gloss powder coated or chromed
verniciatura a polveri lucida o cromata

colours / colori

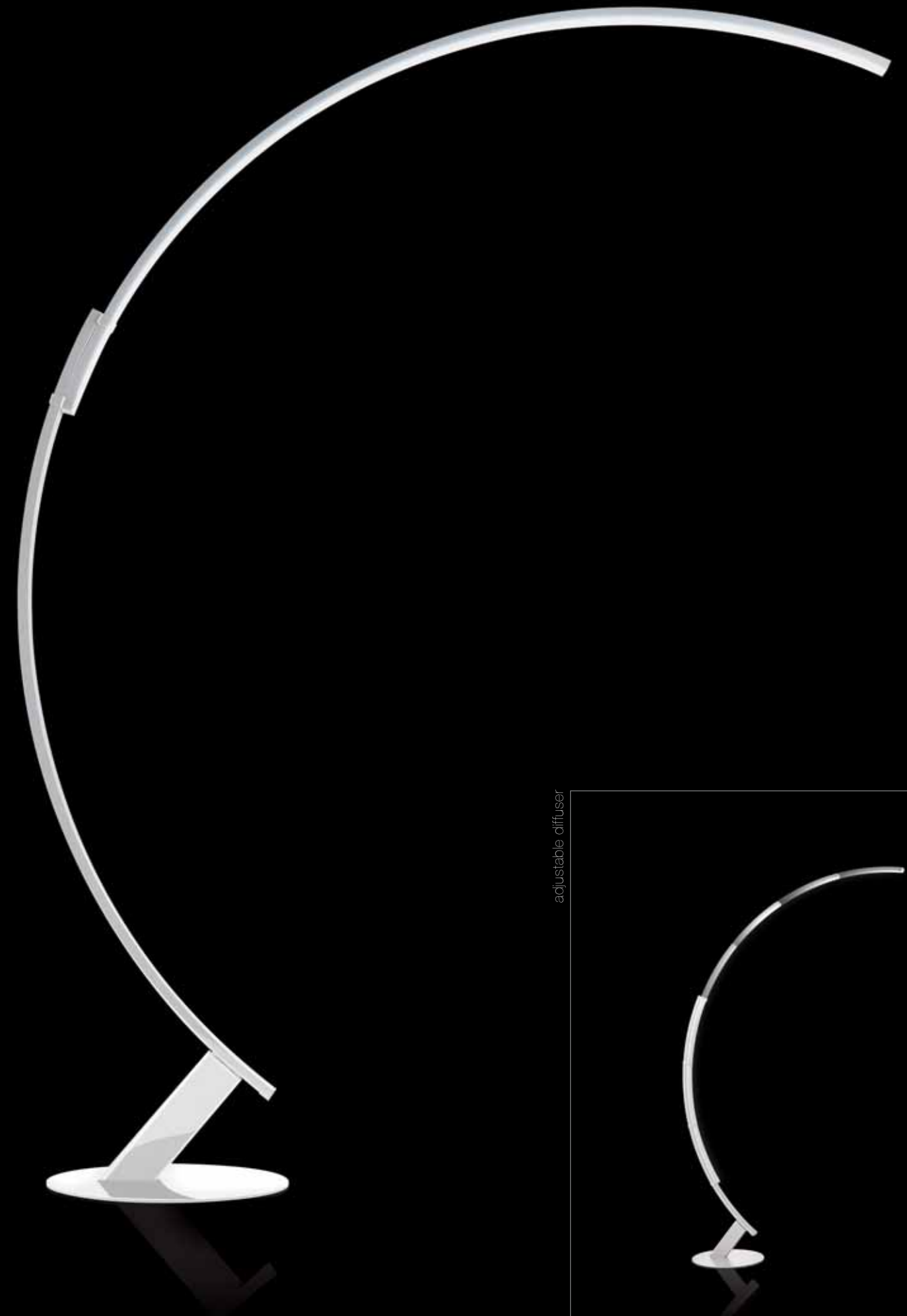

adjustable diffuser

SPILLO *floor /*
CONSTANTIN WORTMANN / 2010



SPIILLO *floor* /

CONSTANTIN WORTMANN / 2010

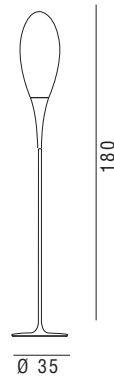

Floor lamp. Rotational-moulded polyethylene diffuser.
Powder coated metal structure and base.

Lampada da terra. Diffusore in polietilene stampato
in rotazionale. Struttura e base in metallo verniciato a
polveri.

Stehleuchte. Mit Polyethylen diffuser in Rotomoulding.
Struktur und Basis aus pulverlackiertem Stahl.

certifications / certificazioni

CE IP20

bulbs / lampadine

1 x 21W E27(E26US) Fluor

feeding / alimentazione

230 / 120 V

dimensions / dimensioni

Ø 35 cm - H 180 cm

finishing / finitura

gloss powder coated
verniciatura a polveri lucida

colours / colori



white

Lampadaire. Diffuseur en polyéthylène moulé par rota-
tion. Structure et base en métal avec application de
peinture en poudre.

Lámpara de pie. Difusor de polietileno estampado en
rotacional. Estructura y base de metal barnizado con
polvos.

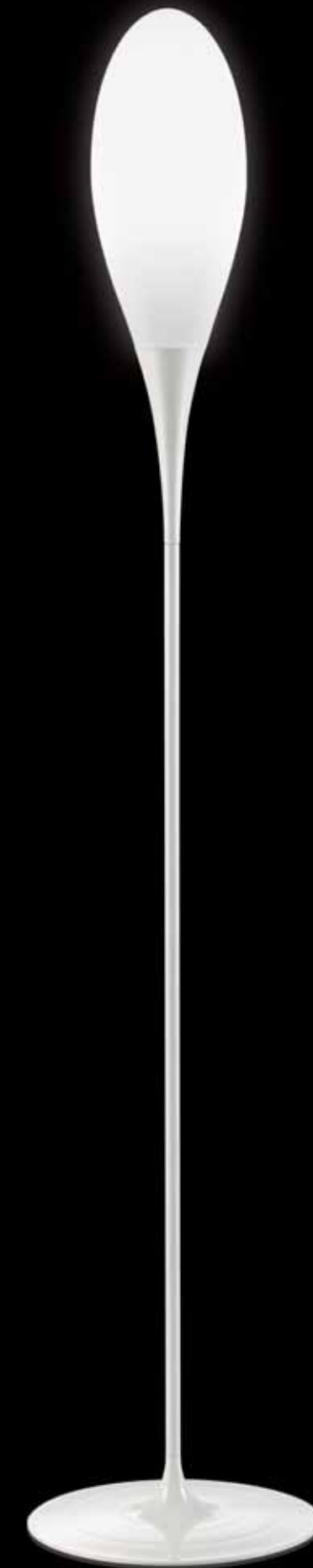

SPILLO *outdoor* /
CONSTANTIN WORTMANN / 2010



SPILLO *outdoor floor* /
CONSTANTIN WORTMANN / 2010



SPILLO *outdoor fix /*
CONSTANTIN WORTMANN / 2010



SPILLO *outdoor* /

CONSTANTIN WORTMANN / 2010

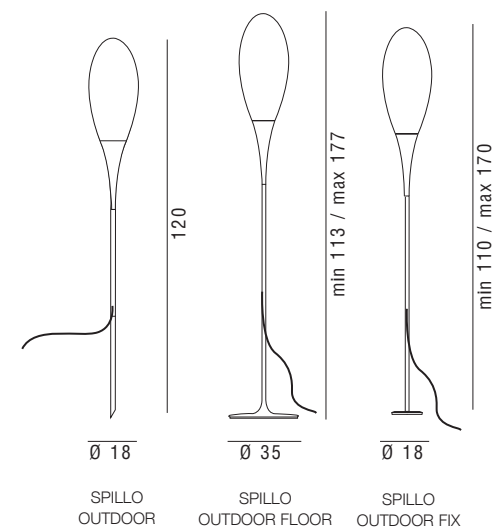

Outdoor floor lamp (IP65). Rotational-moulded polyethylene diffuser. Orange neoprene cord set with IP65 connector. Available with either a peg to enable installation into the ground, a base or a surface mounted base.

Lampada da terra per esterni (IP65). Diffusore in polietilene stampato in rotazionale. Cavo elettrico in neoprene arancione con connettore IP65. Disponibile nella versione a picchetto, con base o con dispositivo fissabile a pavimento.

Außenbodenleuchten (IP65). Mit Polyethylen diffuser in Rotomoulding. Orangefarbenes Neoprenkabel mit IP 65 Verbindungseinheit. Wahlweise verfügbar mit Bodenspieß, Bodenplatte oder verschraubbarer Bodenplatte.

Lampadaire pour extérieur (IP65). Diffuseur en polyéthylène moulé par rotation. Câble électrique en néoprène orange avec dispositif de connexion IP65. Disponible avec piquet, à poser ou avec une système de fixation au sol.

Lámpara de pie para exteriores (IP65). Difusor de polietileno estampado en rotacional. Cable eléctrico de neopreno color naranja con conexión IP65. Disponible en la versión con piqueta, con base o con dispositivo de fijación a suelo.

certifications / certificazioni



dimensions / dimensioni

OUTDOOR | Ø 18 cm - H 120 cm
 OUTDOOR FLOOR | Ø 35 cm - H 113/177 cm
 OUTDOOR FIX | Ø 18 cm - H 110/170 cm

bulbs / lampadine

1 x 21W E27(E26US) Fluor

finishing / finitura

gloss powder coated
 verniciatura a polveri lucida

feeding / alimentazione

230 / 120 V

colours / colori



white

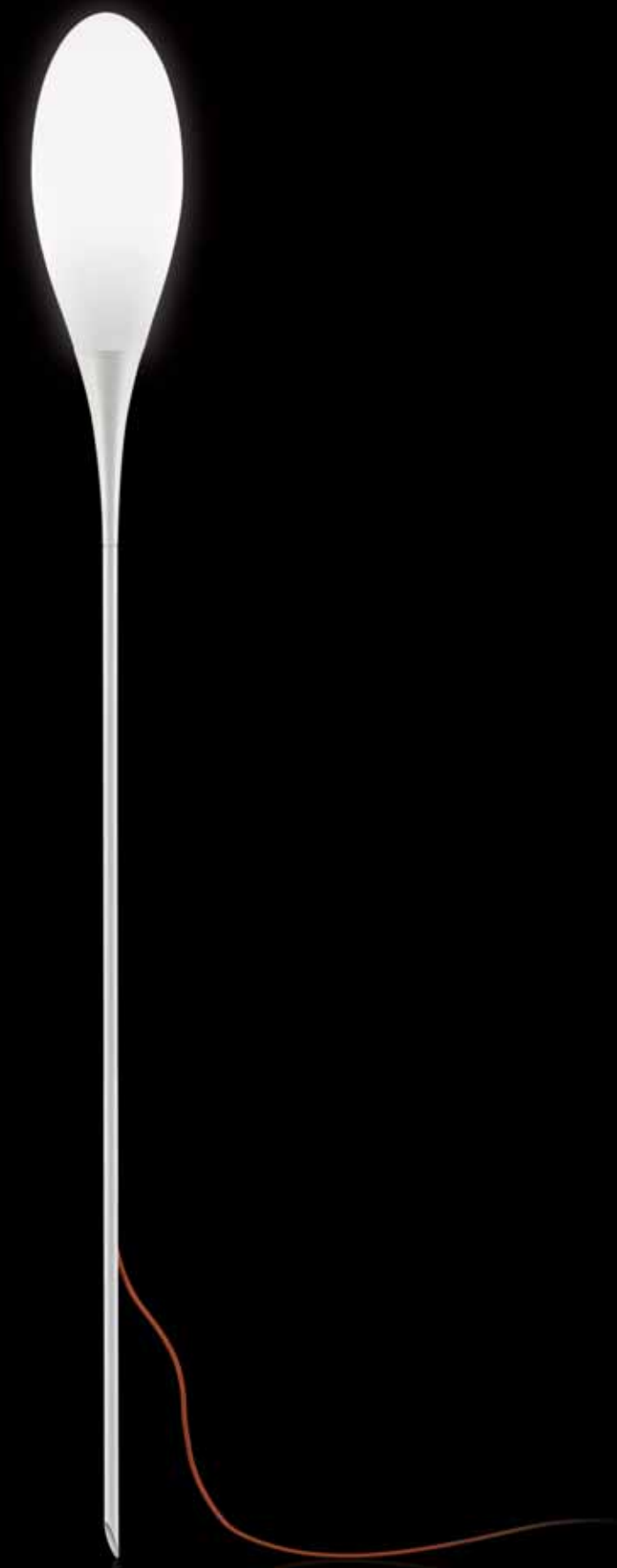

HOMOLOGY

GIORGIO GURIOLI / 2009



HOMOLOGY

GIORGIO GURIOLI / 2009

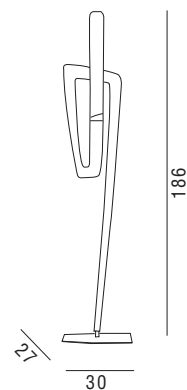

Floor lamp with compact polyurethane body and steel core. Opalescent thermoformed Plexiglas shade, laser cut stainless steel polished base.

Lampada da terra con corpo in poliuretano compatto e anima d'acciaio. Diffusore in Plexiglas opale termoformato, base in acciaio lucidato e tagliato a laser.

Stehleuchte aus kompaktem Polyurethan mit Metallkern. Diffusor aus tiefgezogenem Plexiglas, Sockel Edelstahl poliert.

Lampadaire en polyuréthane compact et structure en métal. Diffuseur en Plexiglas opale thermoformé et base en acier poli coupé laser.

Lámpara de pie con cuerpo de poliuretano compacto y alma de acero. Difusor de Plexiglás ópalo termoformado, base de acero enlucido y cortado con láser.

certifications / certificazioni

□ C E IP20

bulbs / lampadine

1 x 55W 2G11 Fluo

feeding / alimentazione

230 / 120 V

dimensions / dimensioni

L 30 cm - H 186 cm - W 27 cm

finishing / finitura

matt liquid varnished + stainless steel polished base
verniciatura a liquido opaca + base in acciaio lucidato

colours / colori

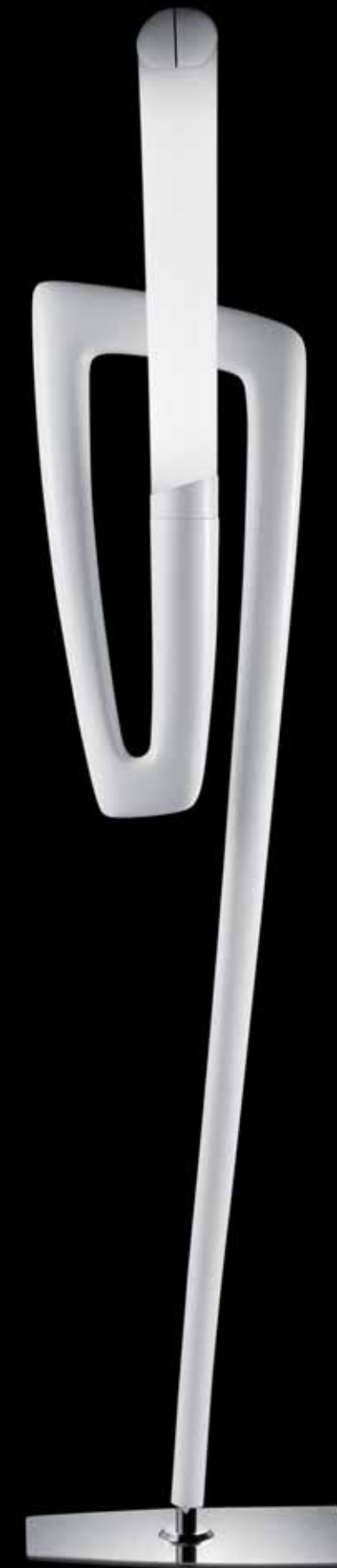
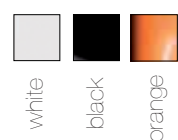

GINA *floor* /

L.LONGO & A.ROMANO - DE-SIGNUM / 2009



GINA *floor* /
L.LONGO & A.ROMANO - DE-SIGNUM / 2009

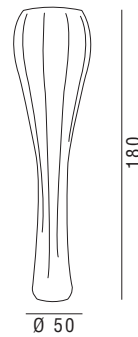

180

Ø 50

Floor lamp. Elasticized vinyl-covered fabric, cloth-covered metal structure.

Lampada da terra. Struttura in metallo rivestita in tessuto spalmato elasticizzato.

Stehleuchte mit vinyl beschichtete Gewebe auf Metallrahmen.

Lampe de terre. Structure en métal recouverte de tissu enduit elastique.

Lámpara de pie. Estructura de metal recubierta de tejido untado elástico.

certifications / certificazioni

□ C E IP20

dimensions / dimensioni

Ø 50 cm - H 180 cm

bulbs / lampadine

3 x 21W E27(E26US) Fluo

finishing / finitura

vinyl-covered fabric
tessuto spalmato

feeding / alimentazione

230 / 120 V

colours / colori



white

black

silver

gold



FLOOR

KARIM RASHID / 2005



FLOOB

KARIM RASHID / 2005

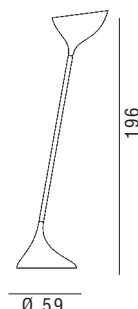

Uplighter in thermoformed and extruded Plexiglas with spun aluminium reflector.

Lampada da terra a luce indiretta in Plexiglas termoformato ed estruso con riflettore in alluminio tornito.

Stehleuchte aus thermogeformtem, extrudiertem und geblasenem Plexiglas.

Lampe en Plexiglas thermoformé, extrudé et soufflé.

Lámpara de pie de luz indirecta de Plexiglas termoformato y extrudido con reflector de aluminio torneado.

certifications / certificazioni



bulbs / lampadine

1 x 200W E27(E26US)
Clear Tubular Halogen

feeding / alimentazione

230 / 120 V

dimensions / dimensioni

Ø 59 cm - H 196 cm

finishing / finitura

gloss
lucida

colours / colori



EERO floor /

LUDOVICA & ROBERTO PALOMBA / 2000



EERO *floor* /
LUDOVICA & ROBERTO PALOMBA / 2000

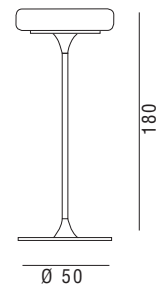

Floor lamp, structure in white painted metal. Diffuser in mouth blown acid etched glass.

Lampada da terra, struttura in metallo verniciato bianco. Diffusore in vetro soffiato e acidato.

Stehleuchte, weiss lackierte Metalstruktur. Diffuser in mundgeblasenem und geätztem Glas.

Lampe de terre, structure en métal verni blanc. Diffuseur en verre soufflé et acidé.

Lámpara de pie, estructura de metal barnizado blanco. Difusor de vidrio soplado y acidado.

certifications / certificazioni

□ C E IP20

dimensions / dimensioni

Ø 50 cm - H 180 cm

bulbs / lampadine

4 x 48W G9 Clear Halogen

finishing / finitura

matt powder coated + acid etched glass
verniciatura a polvere opaca + vetro acidato

feeding / alimentazione

230 / 120 V

colours / colori



white

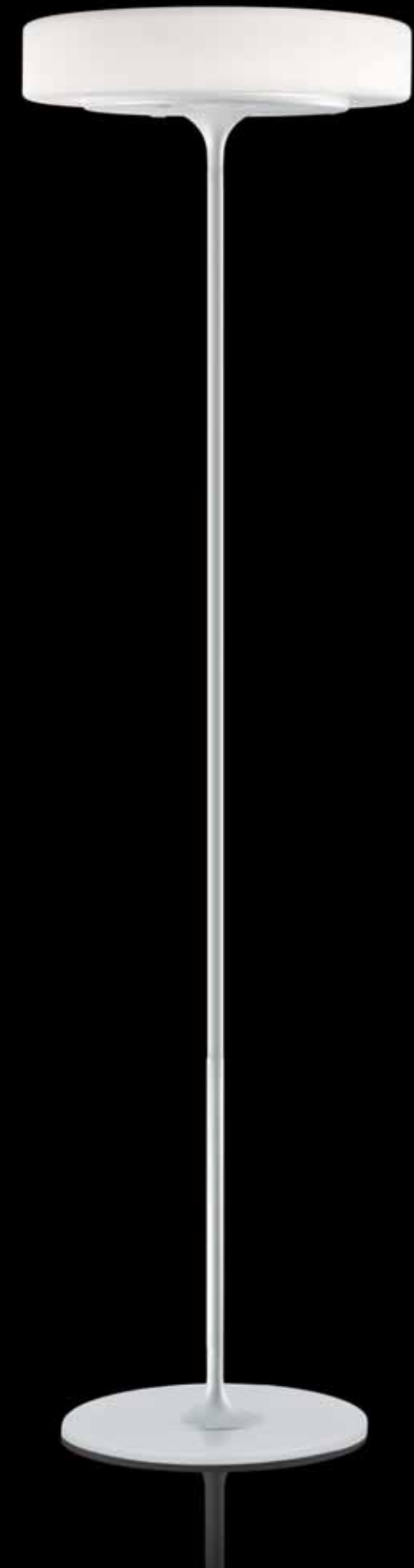

LUMINAL

LAURA AGNOLETTO | MARZIO RUSCONI CLERICI / 2006



LUMINAL

LAURA AGNOLETTO | MARZIO RUSCONI CLERICI / 2006

Floor lamp with blown and laser-cut Plexiglas diffuser, fixed on a metal structure with conic spun fixtures and a stem coated with transparent Plexiglas extruded tube.

Lampada da terra con diffusore in Plexiglas soffiato e tagliato a laser, fissato su struttura metallica con particolari conici torniti in lastra e verniciati e stelo rivestito da tubo estruso in Plexiglas trasparente.

Stehleuchte mit geblasenem und lasergeschnittenem Plexiglasdiffuser, Metallstiel überzogen mit Plexiglasröhre auf konischen Aluminiumteilen fixiert.

Lampe de terre avec un diffuseur en Plexiglas soufflé et coupé laser, monté sur une structure en métal avec des détails coniques repoussés et vernis. Tige enrobée dans un tube extrudé en Plexiglas transparent.

Lámpara de pie con difusor de Plexiglás soplado y cortado con láser, fijado sobre estructura metálica con detalles cónicos torneados en plancha y barnizados y pie revestido por un tubo extrudido de Plexiglás transparente.

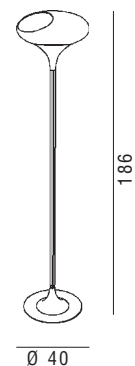

certifications / certificazioni

□ C E IP20

bulbs / lampadine

1 x 200W E27(E26US)
Clear Tubular Halogen

feeding / alimentazione

230 / 120 V

dimensions / dimensioni

Ø 40 cm - H 186 cm

finishing / finitura

gloss powder coated
verniciatura a polveri lucida

colours / colori



white

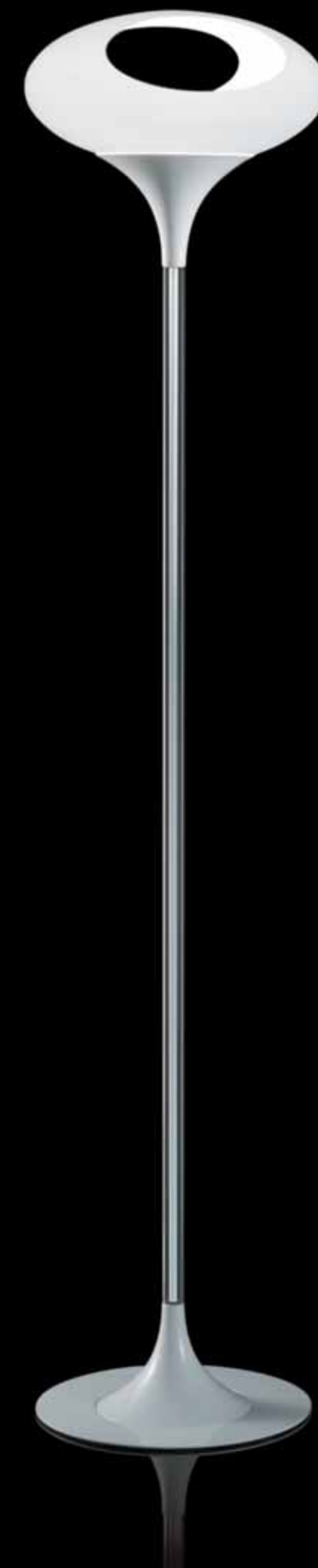

LA LA LAMP

HELEN KONTOURIS / 2004



LA LA LAMP

HELEN KONTOURIS / 2004

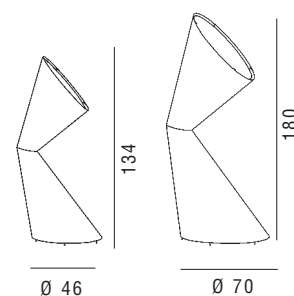

Ø 46 Ø 70

dimensions / dimensioni

S | Ø 46 cm - H 134 cm
L | Ø 70 cm - H 180 cm

finishing / finitura

fabric
tessuto

colours / colori

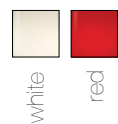

white

red

Floor lamp made of two conic internally opaline coated fabric shades.

Lampada da terra composta da due riflettori conici in tessuto accoppiato a materiale plastico opalino.

Stehleuchte aus zwei konischen, außen textilbezogenen Reflektoren.

Lampe composée de deux réflecteurs coniques en tissu couplé à du matériel plastique opaline.

Lámpara de pie compuesta por dos reflectores cónicos de tejido combinado con material plástico opalino.

certifications / certificazioni



bulbs / lampadine

S | 2 x 21W E27(E26US) Fluor
L | 2 x 25W E27(E26US) Fluor

feeding / alimentazione

230 / 120 V



TRIPOD *floor* /
CHRISTOPHE PILLET / 2002



TRIPOD *floor* /

CHRISTOPHE PILLET / 2002

Floor lamp, structure in grey or white painted metal. Shade in fire resistant fabric closed by an anodized perforated aluminium disc.

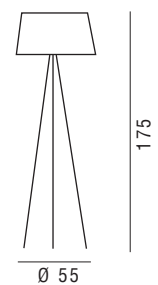

Lampada da terra, struttura in metallo verniciato grigio o bianco. Paralume in tessuto ignifugo chiuso da disco in alluminio microforato e anodizzato.

Stehleuchte, grau oder weiss lackierte Metallstruktur. Diffuser in feuerfestem Stoff, von durchlöcherter eloxierter Aluminiumscheibe verschlossen.

Lampe de terra, structure en métal verni gris ou blanc. Diffuseur en tissu ignifuge fermé par un disque en aluminium micropercé anodisé.

Lámpara de pie, estructura de metal barnizado gris o blanco. Pantalla de tejido ignifugo fijada con disco de aluminio microperforado y anodizado.

certifications / certificazioni



dimensions / dimensioni

Ø 55 cm - H 175 cm

bulbs / lampadine

3 x 80W E27(E26US)
Clear Tubular Halogen
OR 3 x 21W E27 (E26US) Fluor

finishing / finitura

painted metal + fabric
metallo verniciato + tessuto

feeding / alimentazione

230 / 120 V

colours / colori

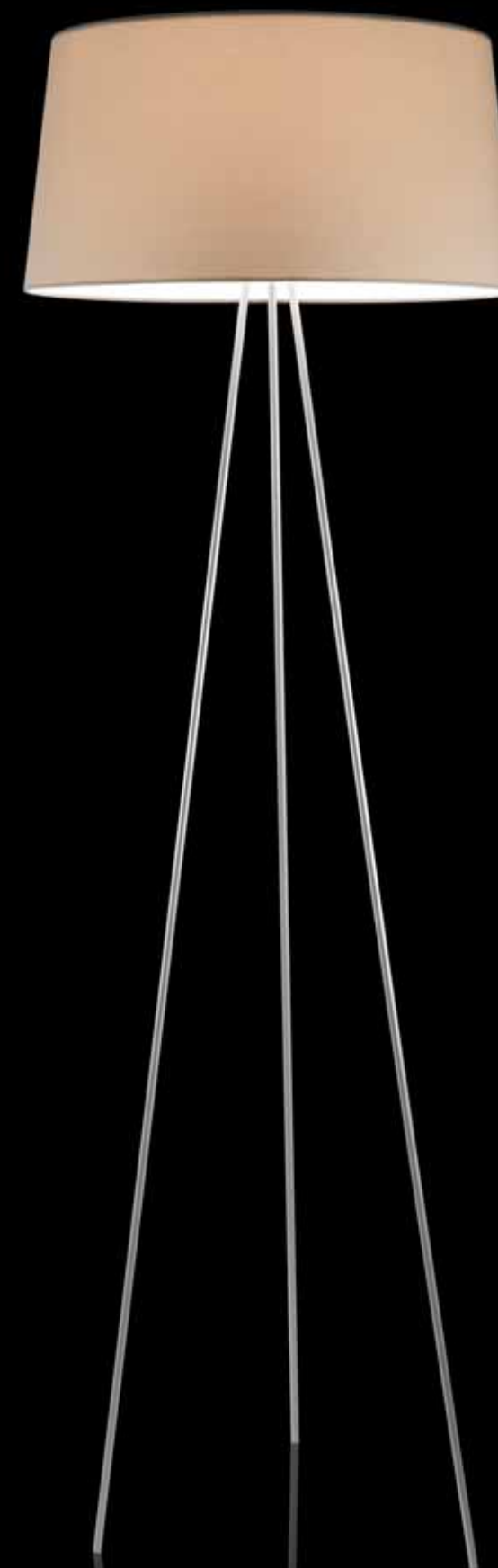
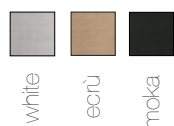

SHAKTI

MARZIO RUSCONI CLERICI / 2001



SHAKTI

MARZIO RUSCONI CLERICI / 2001

Shakti is a floor lamp with two lights for reading and ambient that can be dimmed. The light diffuser is a laser cut extruded Plexiglas tube, fixed into a satin finished or polished stainless steel base. Thanks to the new technology of co-extrusion Shakti's light is always white, even in the coloured versions.

Lampada dimmerabile a due luci, lettura e ambiente, con diffusore tubolare in Plexiglas tagliato a laser e fissato su base d'acciaio satinata o lucidata. Grazie all'innovazione tecnologica della coestrusione, Shakti emana sempre una luce bianca, anche nelle versioni colorate.

Shakti ist eine Stehleuchte mit zwei dimmbaren Glühlampen, die sowohl Leselicht als auch Umgebungslicht spendet. Der Diffuser ist eine extrudierte und lasergeschnittene Plexiglasröhre, welche wahlweise in einer satinierten oder Edelstahl polierten Basis fixiert werden kann. Dank der neuen Technologie der Koextrusion, ist das Licht von Shakti immer weiß, auch in den farbigen Versionen.

Lampe dimmerable de terre à deux lumières et un variateur de lumière, lecture et ambiance, avec un diffuseur tubulaire en Plexiglas coupé laser et fixé sur une base satinée ou en acier poli. Grâce à la nouvelle technologie de la coextrusion, la lumière de Shakti est toujours blanche, même dans le versions en couleurs.

Lámpara con dimmer de dos luces, para lectura y ambiente, con difusor tubular de Plexiglas cortado con láser y fijado sobre base de acero satinado o enlucido. Gracias a la innovación tecnológica de la co-extrusión, Shakti emana siempre una luz blanca, incluso en las versiones de colores.

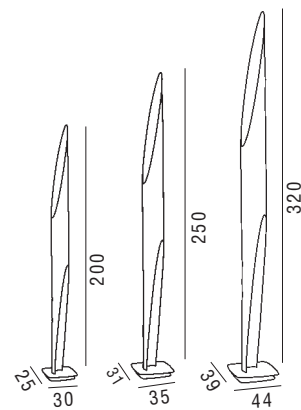

certifications / certificazioni



bulbs / lampadine

200 2 x 80W E27 (E26US) Clear Tubular Halogen
OR 2 x 21W E27 (E26US) Fluo
250 2 x 120W E27 (E26US) Clear Tubular Halogen
OR 2 x 25W E27 (E26US) Fluo
320 2 x 120W E27 (E26US) Clear Tubular Halogen
OR 2 x 25W E27 (E26US) Fluo

feeding / alimentazione

230 / 120 V

dimensions / dimensioni

200 | L 30 cm - H 200 cm - W 25 cm
250 | L 35 cm - H 250 cm - W 31 cm
320 | L 44 cm - H 320 cm - W 39 cm

finishing / finitura

gloss
lucida



colours / colori

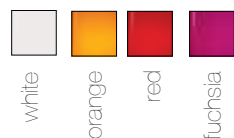

TORIC *floor* /
PATRICK NORGUET / 2003



TORIC *floor* /

PATRICK NORGUET / 2003

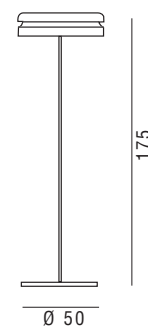

Floor lamp with direct light. Structure in white painted metal. Reflector in black/white or orange/white painted metal. Glass diffuser.

Lampada da terra a luce diretta. Struttura in metallo verniciato bianco. Riflettore in metallo verniciato bianco/arancio o bianco/nero. Diffusore in vetro.

Stehleuchte mit direktem Licht. Weiss lackierte Metallstruktur. Reflektor in weiss-orangem oder weiss-schwarzem Metall Glasdiffuser.

Lampe de terre avec lumière directe. Structure en métal verni blanc. Réflecteur en métal verni blanc/orange ou blanc/noir. Diffuseur en verre.

Lámpara de pie de luz directa. Estructura de metal barnizado blanco. Reflector de metal barnizado blanco/naranja o blanco/negro. Difusor de vidrio.

certifications / certificazioni



dimensions / dimensioni

Ø 50 cm - H 175 cm

bulbs / lampadine

4 x max 48W G9 Clear Halogen

finishing / finitura

gloss powder coated
verniciatura a liquido lucida

feeding / alimentazione

230 / 120 V

colours / colori

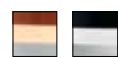

white/orange

white/black

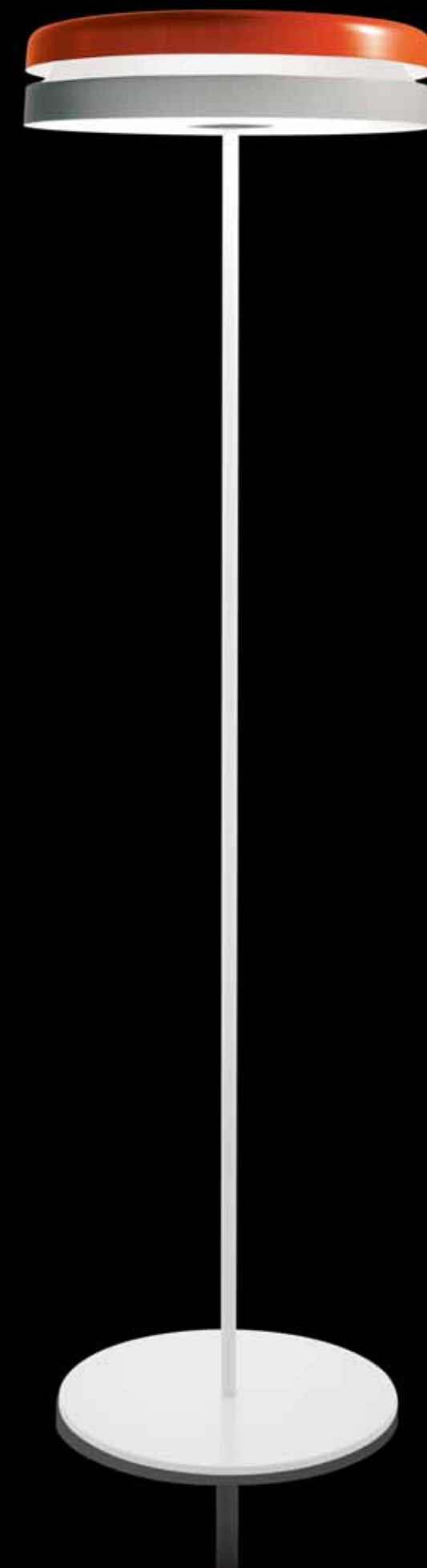

SAMA
GREGORIO SPINI / 2003



SAMA

GREGORIO SPINI / 2003

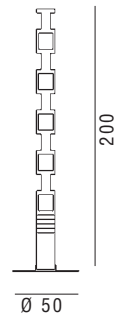

Floor lamp in two tone coextruded and laser cut Plexiglas, inserted in a chrome plated steel base.

Lampada da terra in Plexiglas bicolore coestruso e tagliato a laser, inserita in una base d'acciaio cromato.

Stehleuchte mit einem zweifarbig coextrudierten laser-geschnittenen Plexiglasdiffuser. Stahlfuß verchromt.

Lampe de terre en Plexiglas bi-couleur co-extrusé coupé laser, introduit dans une base en acier chromé.

Lámpara de pie de Plexiglás bicolor co-extrudido y cortado con láser, colocada sobre una base de acero cromado.

certifications / certificazioni

CE IP20

bulbs / lampadine

1 x 100W E27(E26US)
PAR30 Halogen Dichroic

feeding / alimentazione

230 / 120 V

dimensions / dimensioni

Ø 50 cm - H 200 cm

finishing / finitura

gloss
lucida

colours / colori

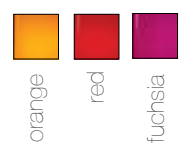

ASANA
GIORGIO GURIOLI / 2004



ASANA

GIORGIO GURIOLI / 2004

certifications / certificazioni

□ C E IP20

bulbs / lampadine

1 x 200W E27 (E26US)
Clear Tubular Halogen

feeding / alimentazione

230 / 120 V

dimensions / dimensioni

L 67 cm - H 205 cm - W 64 cm

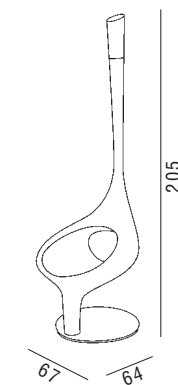

finishing / finitura

lacquered
laccata

colours / colori



Floor lamp in lacquered fibreglass with an integrated seat fixed onto a polished steel base. Diffuser in Murano triplex blown glass.

Lampada da terra in vetroresina laccata con seduta integrata e diffusore in vetro di Murano soffiato triplex, fissata su base in acciaio lucidato.

Stehleuchte mit integriertem Sessel aus lackiertem Fieberglas, befestigt auf einer polierten Stahlbasis. Diffuser aus geblasenem Triplex Muranoglas.

Lampe de terre en fibre de verre laquée avec un siège intégré fixé sur une base en acier poli et avec un diffuseur en verre de Murano soufflé triplex.

Lámpara de pie de resina de vidrio lacada con asiento integrado y difusor de cristal de Murano soplado triplex, fijada sobre base de acero enlucido.



E.T.A.

GUGLIELMO BERCHICCI / 1996



E.T.A.

GUGLIELMO BERCHICCI / 1996

Floor lamp. Handmade light diffuser in ecological fibreglass, metallic inner structure (removable for bulbs changing), dimmer.

Lampada da terra. Corpo diffusore in vetroresina ecologica lavorato a mano, struttura interna in metallo (rimovibile per la sostituzione delle lampadine), dimmer.

Stehleuchte. Handgemachter Diffusor aus ökologischem Fiberglas, interne metallene Leuchtmittelhalterung (herausnehmbar um die Leuchtmittel auszuwechseln), dimmer.

Lampe de terre. Diffuseur en fibre de verre écologique fait à la main, structure intérieure en métal (déplaçable pour changer les ampoules), variateur de lumière.

Lámpara de pie. Cuerpo difusor de resina de vidrio ecológica trabajado a mano, estructura interna de metal (extraíble para poder sustituir las bombillas), dimmer.

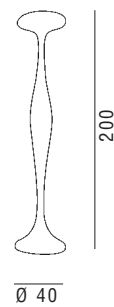

Ø 40

200

certifications / certificazioni



bulbs / lampadine

3 x 40W E14(E12US) Clear Olive
1 x 120W E27(E26US)
Clear Tubular Halogen

feeding / alimentazione

230 / 120 V

dimensions / dimensioni

Ø 40 cm - H 200 cm

finishing / finitura

coloured fibreglass
vetroresina colorata

colours / colori

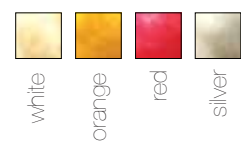

YOGA
GUGLIELMO BERCHICCI / 1997



YOGA

GUGLIELMO BERCHICCI / 1997

certifications / certificazioni

□ CE IP20

bulbs / lampadine

3 x 40W E14(E12US) Clear Olive
1 x 120W E27(E26US)
Clear Tubular Halogen

feeding / alimentazione

230 / 120 V

dimensions / dimensioni

Ø 40 cm - H 200 cm

finishing / finitura

coloured fibreglass
vetroresina colorata

colours / colori

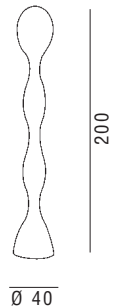
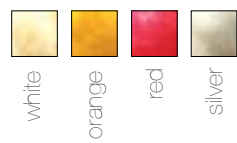

Floor lamp. Handmade light diffuser in ecological fibreglass, metallic inner structure (removable for bulbs changing), dimmer.

Lampada da terra. Corpo diffusore in vetroresina ecologica lavorato a mano, struttura interna in metallo (rimovibile per la sostituzione delle lampadine), dimmer.

Stehleuchte. Handgemachter Diffusor aus ökologischem Fiberglas, interne metallene Leuchtmittelhalterung (herausnehmbar um die Leuchtmittel auszuwechseln), dimmer.

Lampe de terre. Diffuseur en fibre de verre écologique fait à la main, structure intérieure en métal (déplaçable pour changer les ampoules), variateur de lumière.

Lámpara de pie. Cuerpo difusor de resina de vidrio ecológica trabajado a mano, estructura interna de metal (extraíble para poder sustituir las bombillas), dimmer.



ATOMIUM

HOPF&WORTMANN - BÜRO FÜR FORM / 2006



ATOMIUM

HOPF&WORTMANN - BÜRO FÜR FORM / 2006

Table and floor lamp with rotational-moulded polyethylene diffuser and inner structure with six light sources fixed on steel coil springs.

Lampada da tavolo e da terra con diffusore in polietilene stampato in rotazionale e struttura interna a sei luci montate su molle tensionate in acciaio.

Tisch- und Bodenleuchte mit Polyethylen diffuser in Rotomoulding, innen Federstruktur aus Stahl mit sechs Lampen.

Lampe de table e de terre avec un diffuseur en polyéthylène imprimé en rotoroulage et une structure intérieure à six luminaires placées sur des ressorts tensionnés en acier.

Lámpara de mesa y de pie con difusor de polietileno estampado en rotacional con estructura interna de seis luces montadas sobre resortes tensados de acero. Cable autoportante con alma de acero.

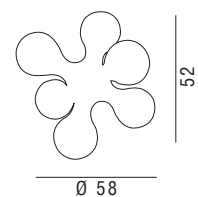



Ø 58

52

certifications / certificazioni

  CE IP20

bulbs / lampadine

 6 x 40W E14(E12US) Clear
 OR 6 x 12W E14(E12US) Fluo

feeding / alimentazione

230 / 120 V

dimensions / dimensioni

Ø 58 cm - H 52 cm

finishing / finitura

gloss
lucida

colours / colori



white

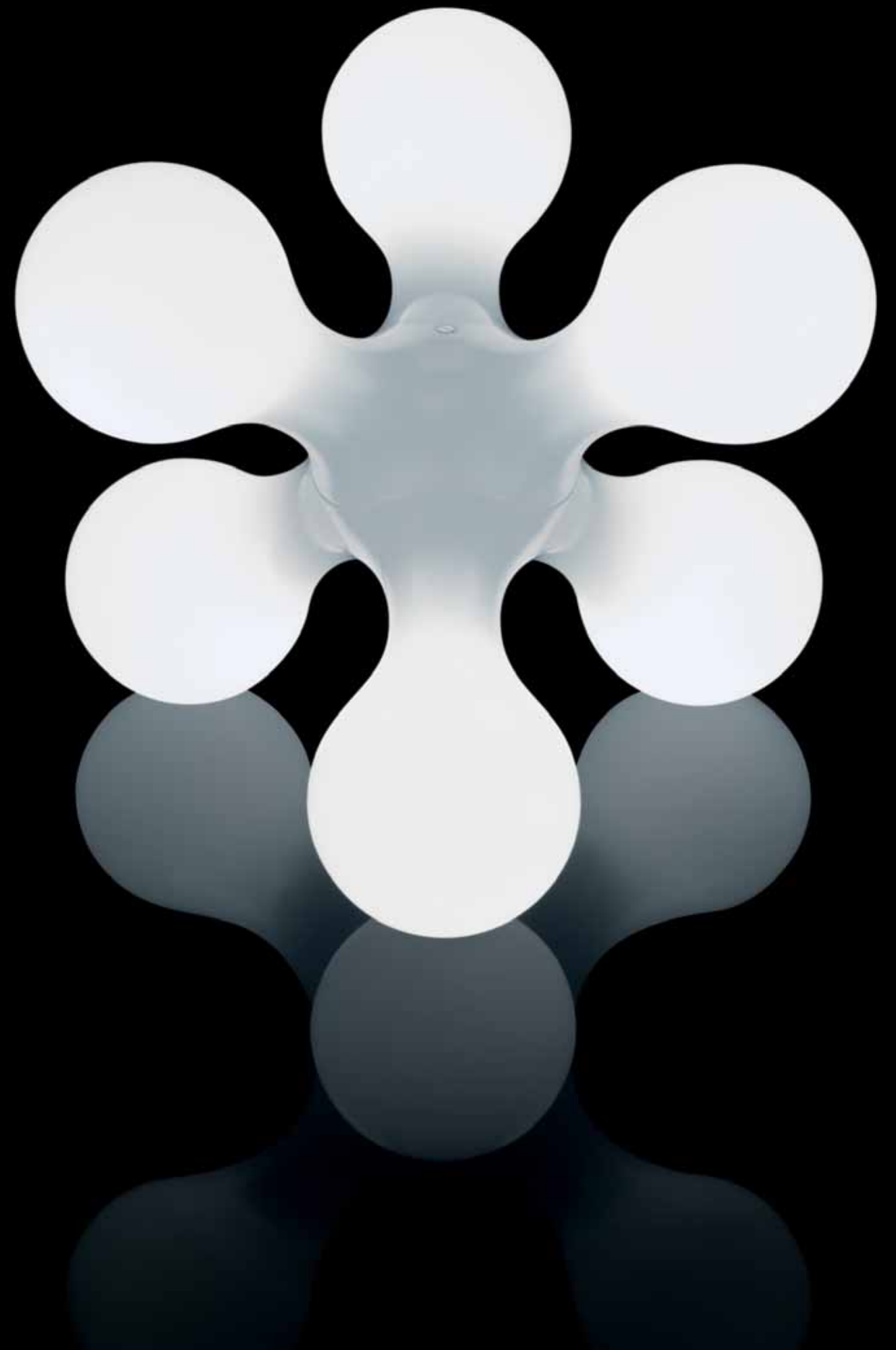

ATOMIUM *outdoor* /
HOPF&WORTMANN - BÜRO FÜR FORM / 2009



ATOMIUM *outdoor* /

HOPF&WORTMANN - BÜRO FÜR FORM / 2009

Outdoor table and floor lamp (IP65). Roto-moulded polyethylene diffuser and inner structure with six light sources fixed on metal antennas. Orange neoprene cord set with IP65 connection device.

Lampada da tavolo e da terra per esterni (IP65). Diffusore in polietilene stampato in rotazionale e struttura interna a sei luci montate su antenne metalliche. Cavo elettrico in neoprene arancione con dispositivo di connessione IP65.

Outdoor Tisch- und Bodenleuchte (Schutzklasse IP65). Polyethlendiffusor (Rotationsguß) mit sechs Lichtquellen. Orangefarbenes Neoprenkabel mit IP65 Verbindungseinheit.

Lampe de table e de terre pour l'extérieur (IP65) avec un diffuseur en polyéthylène imprimé en rotomoulage et d'une structure intérieure de six luminaires. Câble en néoprène orange avec connecteur IP65.

Lámpara de mesa y de pie para exteriores (IP65). Difusor de polietileno estampado en rotacional y estructura interna de seis luces montadas sobre antenas metálicas. Cable eléctrico de neopreno color naranja con dispositivo de conexión IP65.

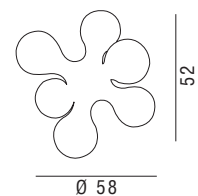



Ø 58

52

certifications / certificazioni

  IP65

bulbs / lampadine

 6 x 40W E14(E12US) Clear
 OR 6 x 12W E14(E12US) Fluo

feeding / alimentazione

230 / 120 V

dimensions / dimensioni

Ø 58 cm - H 52 cm

finishing / finitura

gloss
lucida

colours / colori



white

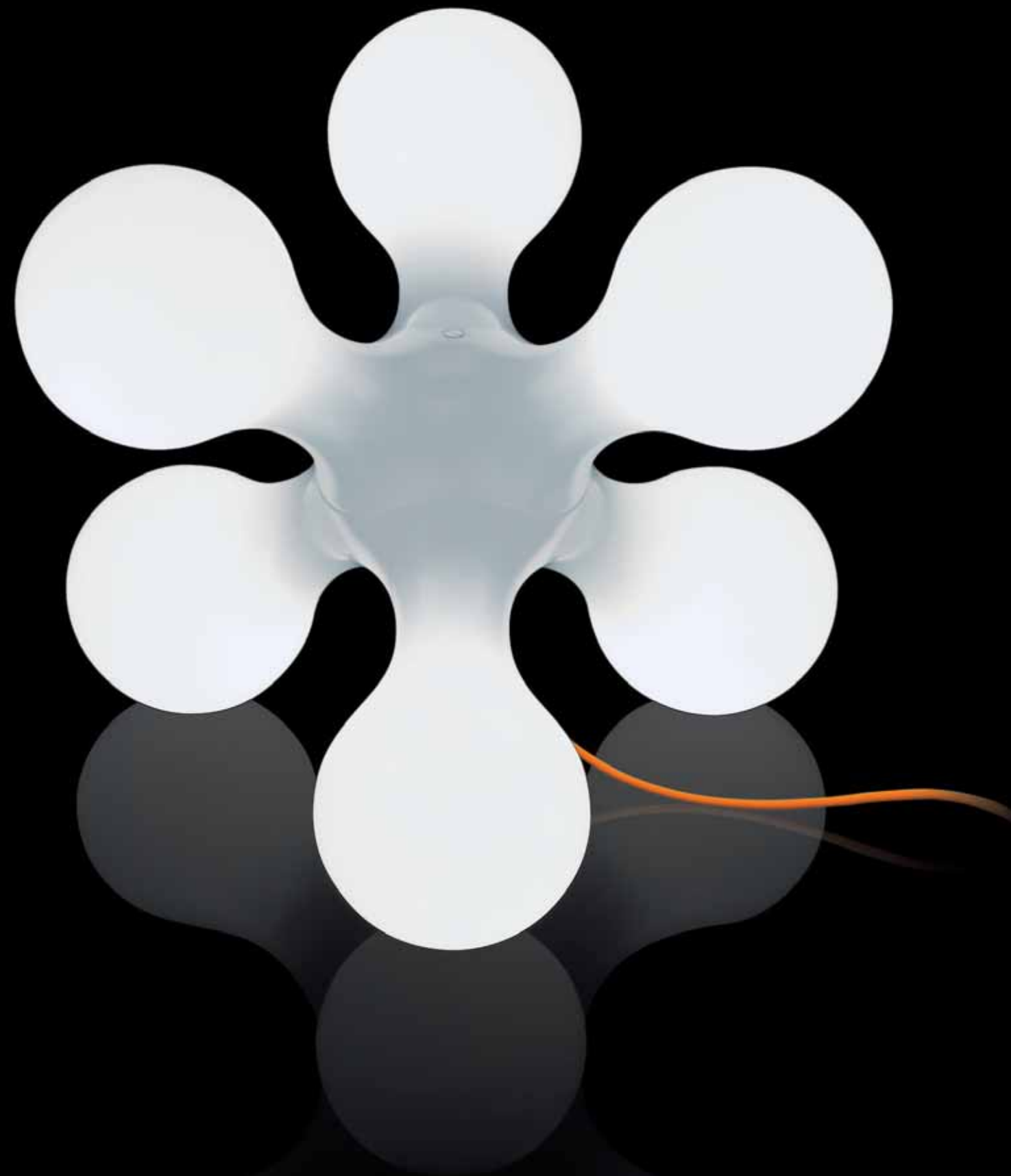

LINEA

PATRIZIO ORLANDI / 2008



LINEA

PATRIZIO ORLANDI / 2008

* accessories / accessori

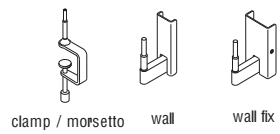

clamp / morsetto wall wall fix

certifications / certificazioni



bulbs / lampadine

1 x 4W Power Led
6300 K pure white

feeding / alimentazione

230 / 120 V

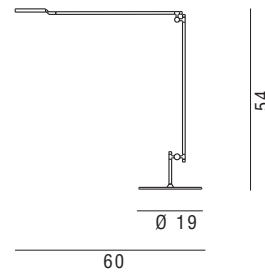

dimensions / dimensioni

L 60 - Ø 19 cm - H 54 cm

finishing / finitura

matt liquid varnished
verniciatura a liquidi opaca

colours / colori

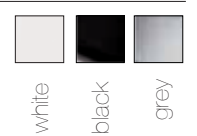

white

black

grey

Table lamp with two cantilevered arms in aluminium. Head in injection moulded polycarbonate with high voltage power led.

Lampada da tavolo a due bracci snodabili in alluminio. Testa in polycarbonato stampato a iniezione con led di potenza a tensione di rete.

Tischleuchte mit zwei beweglichen Arme aus Aluminium. Kopf aus Polycarbonat in Spritzgussform mit Hochvolt Powerled.

Lampe de table avec deux bras articulés en aluminium. Tête en polycarbonato moulé à injection avec led de puissance à haute voltage.

Lámpara de mesa con dos brazos articulables de aluminio. Cabeza de polycarbonato estampado a inyección con led de potencia de tensión de red.



LINEA 1
PATRIZIO ORLANDI / 2008



LINEA 1

PATRIZIO ORLANDI / 2008

* accessories / accessori

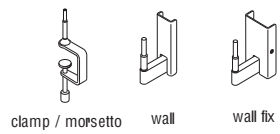

clamp / morsetto wall wall fix

certifications / certificazioni



bulbs / lampadine

1 x 4W Power Led
6300 K pure white

feeding / alimentazione

230 / 120 V

dimensions / dimensioni

Ø 16 cm - H 64 cm

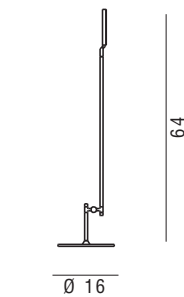

finishing / finitura

matt liquid varnished
verniciatura a liquidi opaca

colours / colori



Table lamp with one cantilevered arm in aluminium. Head in injection moulded polycarbonate with high voltage power led.

Lampada da tavolo in alluminio. Testa in policarbonato stampato a iniezione con led di potenza a tensione di rete.

Tischleuchte aus Aluminium. Kopf aus Polycarbonat in Spritzgussform mit Hochvolt Powered.

Lampe de table en aluminium. Tête en polycarbonate moulé à injection avec led de puissance à haute voltage.

Lámpara de mesa de aluminio. Cabeza de policarbonato estampado a inyección con led de potencia de tensión de red.



ABYSS
OSKO+DEICHMANN / 2007



ABYSS

OSKO+DEICHMANN / 2007

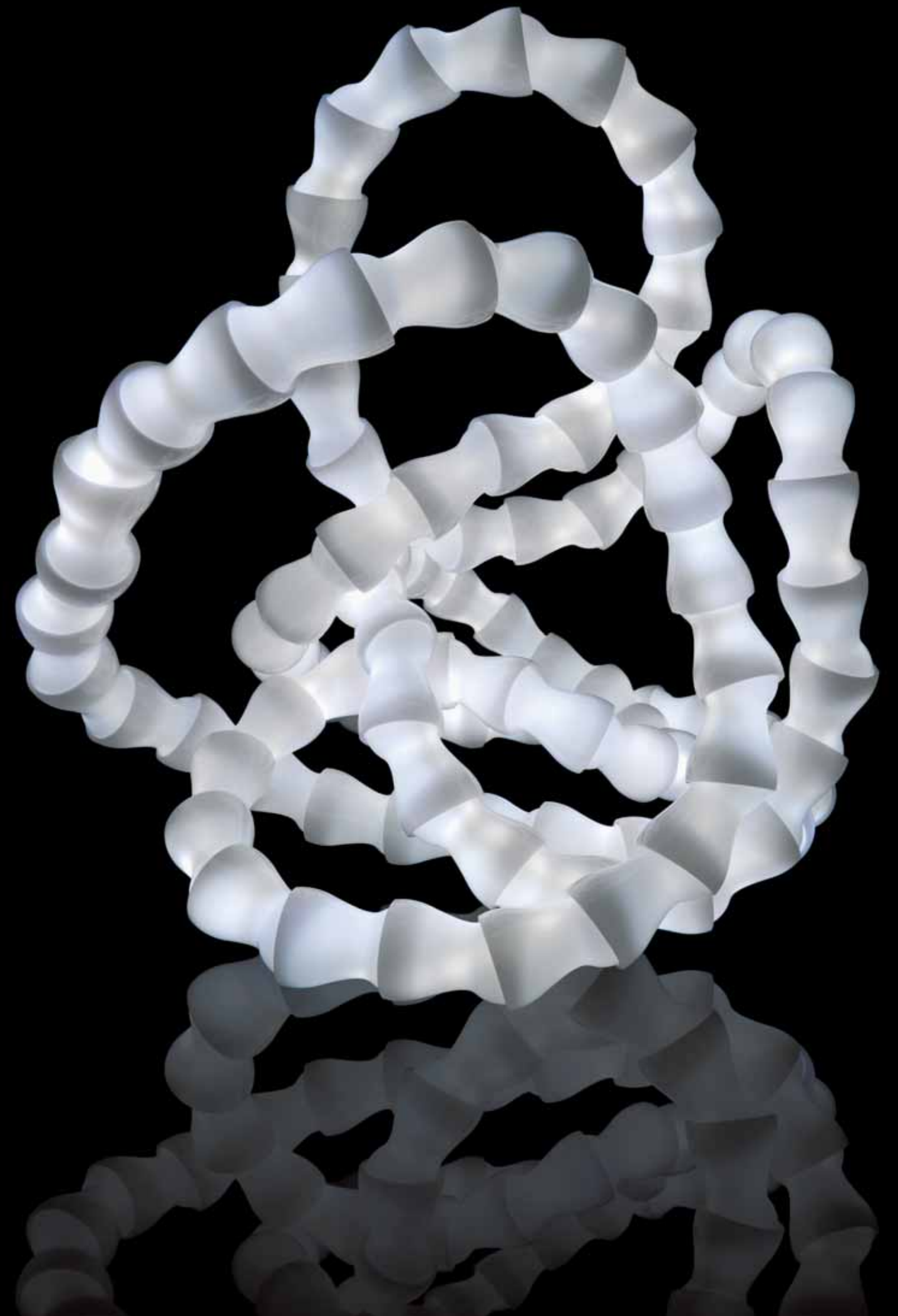

Table lamp with high voltage Led strip and modular structure in injection moulded opal polycarbonate.

Lampada da tavolo con filo di Led a tensione di rete e struttura modulare portante in policarbonato opalino stampato a iniezione.

Tischleuchte mit Hochvolt Led Streifen und Modularstruktur aus opalem Polycarbonat in Spritzgussform.

Lampe de table avec un fil de Led à haute voltage et structure modulaire portante en polycarbonate opale moulé à injection.

Lámpara de mesa con cable de Led de tensión de red y estructura modular portante de policarbonato opalino estampado a inyección.

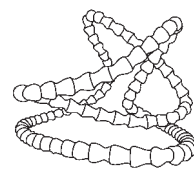

Ø 110

certifications / certificazioni



bulbs / lampadine
1 x 10W Led Strip

feeding / alimentazione
230 / 120 V

dimensions / dimensioni

Ø 110 cm

finishing / finitura

gloss
lucida

colours / colori



white

HONEYMOON *table* /
JOHN SEBASTIAN / 2007



HONEYMOON *table* /

JOHN SEBASTIAN / 2007

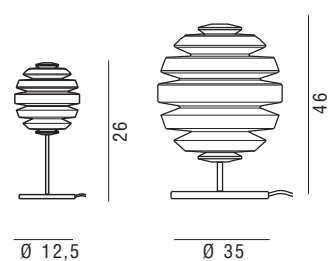

Table lamp with opal mouth blown triplex glass diffuser.
Base in spun opaque-white varnished metal.

Lampada da tavolo con diffusore in vetro opale incamicciato e soffiato. Struttura in metallo tornito verniciato bianco opaco.

Tischleuchte mit Leuchtkörper aus mundgeblasenem, opalem Triplexglas. Metallstruktur in matten weiß lackiert.

Lampe de table au diffuseur en verre opale soufflé triplex. Structure en métal verni blanc opaque.

Lámpara de mesa con difusor de vidrio ópalo enfundado y soplado. Estructura de metal torneado barnizado blanco opaco.

★ Honeymoon table small excluded

certifications / certificazioni

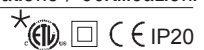

dimensions / dimensioni

S | Ø 12,5 cm - H 26 cm
L | Ø 35 cm - H 46 cm

finishing / finitura

gloss glass + matt powder coated
vetro lucido + verniciatura a polveri opaca

colours / colori



white



ENTROPIA *table /*
LIONEL DEAN / 2006



ENTROPIA *table* /

LIONEL DEAN / 2006

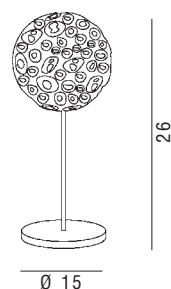

Table lamp with diffuser in laser-sintered nylon built in 1200 layers. Chromeplated metal stem and base.

Lampada da tavolo con diffusore in nylon sinterizzato al laser in 1200 strati. Stelo e base in metallo cromato.

Tischleuchte mit, in 1200 Schichten, lasergesinterter Nylondiffuser. Verchromte Metallteile.

Lampe de table avec un diffuseur en nylon procédé au frittage laser en 1200 couches. Détails en métal chromé.

Lámpara de mesa con difusor de nylon sinterizado al láser en 1200 capas. Pie y base en metal cromado.

certifications / certificazioni

□ C E IP20

bulbs / lampadine

1 x 25W G9 Clear Halogen

feeding / alimentazione

230 / 120 V

dimensions / dimensioni

Ø 15 cm - H 26 cm

finishing / finitura

matt diffuser + chromed base
diffusore opaco + base cromata

colours / colori



white

GHERKIN

NORMAN FOSTER / 2005



GHERKIN

NORMAN FOSTER / 2005

certifications / certificazioni



bulbs / lampadine

30 | 1 x 60W E14 (E12US)
Clear Olive
60 | 1 x 120W E27 (E26US)
Clear Tubular Halogen

feeding / alimentazione

230 / 120 V

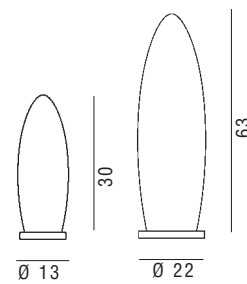

dimensions / dimensioni

30 | Ø 13 cm - H 30 cm
60 | Ø 22 cm - H 63 cm

finishing / finitura

blown or acid etched glass + chromed base
vetro incamiciato o acidato + base cromata

colours / colori



glossy

white

Table lamp with triplex mouth blown glass available also in an acid etched version. Chromed metal base.

Lampada da tavolo con diffusore in vetro incamiciato soffiato e acidato. Disponibile anche in versione acidata. Base in metallo tornito e cromato.

Tischleuchte aus mundgeblasenem und geätztem Triplexglas, mit verchromter Metallbasis.

Lampe de table avec un diffuseur en verre acidé soufflé triplex. Base en acier chromé.

Lámpara de mesa con difusor de vidrio enfundado, soplado y acidado. Base de metal torneado y cromado.

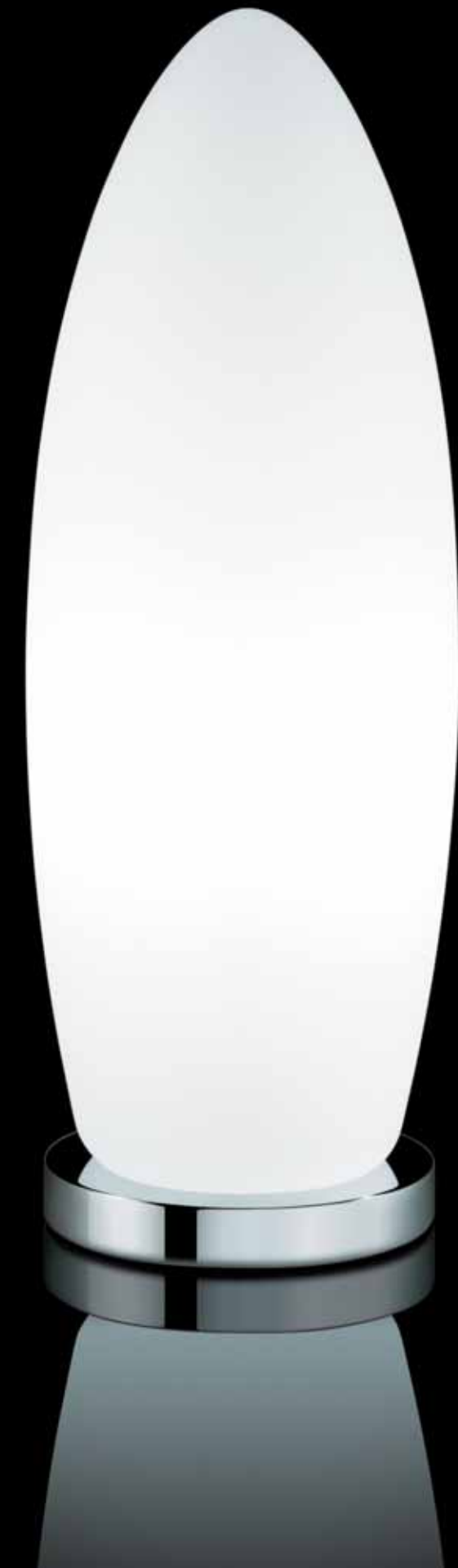

BOKKA

KARIM RASHID / 2005



BOKKA

KARIM RASHID / 2005

certifications / certificazioni

ETL CE IP20

bulbs / lampadine

1 x 120W E27 (E26US)
Clear Tubular Halogen

feeding / alimentazione

230 / 120 V

dimensions / dimensioni

Ø 38 cm - H 63 cm

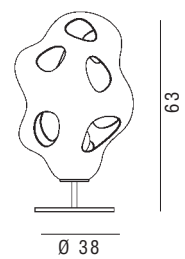

finishing / finitura

gloss glass + chromed base
vetro lucido + base cromata

colours / colori

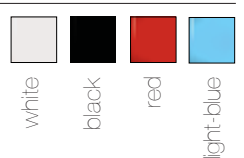

Table lamp with triplex glass diffuser, mouth blown and water jet cut. Chromed metal base.

Lampada da tavolo con diffusore in vetro incamiciato, soffiato e forato a getto d'acqua. Base in metallo cromato.

Tischleuchte mit Leuchtkörper aus mundgeblasenem und Wasserstrahl geschnittenem Triplexglas. Metallfuß verchromt.

Lampe de table à diffuseur en verre, soufflé triplex et troué à jet d'eau. Base en acier chromé.

Lámpara de mesa con difusor de vidrio enfundado, soplado y perforado con chorro de agua. Base de metal cromado.



CANDELA
JUANICO / 2007



CANDELA

JUANICO / 2007

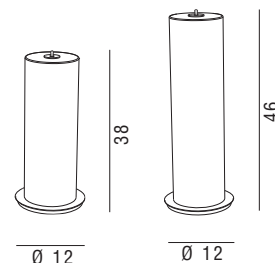

certifications / certificazioni

CE IP20

bulbs / lampadine

S | 1 x 15W E27 (E26US) Fluor
L | 1 x 21W E27 (E26US) Fluor

feeding / alimentazione

230 / 120 V

dimensions / dimensioni

S | Ø 12 cm - H 38 cm
L | Ø 12 cm - H 46 cm

finishing / finitura

opal glass + chromed base
vetro opalino + base cromata

colours / colori



white

Table lamp with opal mouth blown triplex glass diffuser in two heights. Fixture in chromed metal.

Lampada da tavolo con diffusore in vetro opale incamiciato e soffiato in due altezze. Struttura in metallo cromato.

Tischleuchte mit Leuchtkörper aus mundgeblasenem, opalem Triplexglas, in zwei Höhen erhältlich. Verchromte Metallhalterung.

Lampe de table au diffuseur en verre opale soufflé triplex. Structure en métal chromé.

Lámpara de mesa con difusor de vidrio ópalo enfundado y soplado propuesta en dos medidas. Estructura de metal cromado.



NOGLOBE

LAURA AGNOLETTO | MARZIO RUSCONI CLERICI / 2004

Table and floor lamp, made of a white acrylic sphere with three elliptic laser cut holes and chromed metal structure. Functionally, Noglobe spreads an ambience light, soft as well as directional.

Lampada da tavolo e da terra, costituita da una sfera in acrilico bianco con tre fori ellissoidali tagliati a laser e struttura in acciaio tornito e cromato. Dal punto di vista funzionale, Noglobe emana una luce diffusa morbida e al tempo stesso direzionale.

Boden- oder Tischleuchte, die aus einer weißen Plexiglassphäre mit drei elliptischen Laserausschnitten besteht, montiert auf eine verkromte Stahlstruktur. Noglobe strahlt ein weiches und gleichzeitig direktes Licht aus.

Lampe de table ou de terre constituée par une sphère en acrylique blanc avec trois ronds à la forme d'une ellipse coupée laser et structure en acier repoussé et chromé. Au niveau fonctionnel, Noglobe émane une lumière diffusée à la fois douce et directionnelle.

Lámpara de pie o de mesa, constituida por una esfera de acrílico blanco con tres orificios elipsoidales cortados con láser y estructura de acero torneado y cromado. Desde el punto de vista funcional, Noglobe emana una luz difusa suave y al mismo tiempo direccional.

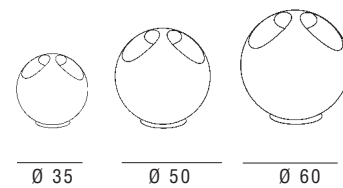

certifications / certificazioni



dimensions / dimensioni

35 | Ø 35 cm
50 | Ø 50 cm
60 | Ø 60 cm

bulbs / lampadine

- 35 | 1 x 21W E27 (E26US) Globo
Fluorescent diam. 102mm
- 50 | 1 x 25W E27 (E26US) Globo
Fluorescent diam. 120mm
- 60 | 3 x 25W E27 (E26US) Globo
Fluorescent diam. 120mm

finishing / finitura

gloss + chromed base
lucida + base cromata

feeding / alimentazione

230 / 120 V

colours / colori



white



TORIC *table* /
PATRICK NORGUET / 2003



TORIC *table* /

PATRICK NORGUET / 2003



Table lamp with direct light. Structure in white painted metal. Reflector in black/white or orange/white painted metal. Glass diffuser.

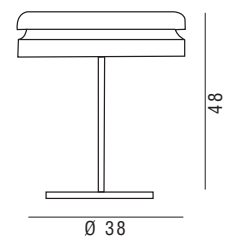

Lampada da tavolo a luce diretta. Struttura in metallo verniciato bianco. Riflettore in metallo verniciato bianco/arancio o bianco/nero. Diffusore in vetro.

Tischleuchte mit direktem Licht. Weiss lackierte Metallstruktur. Reflektor in weiss-orangem oder weiss-schwarzem Metall. Glassdiffuser.

Lampe de table avec lumière directe. Structure en métal verni blanc. Réflecteur en métal verni blanc/orange ou blanc/noir. Diffuseur en verre.

Lámpara de mesa de luz directa. Estructura de metal barnizado blanco. Reflector de metal barnizado blanco/naranja o blanco/nero. Difusor de vidrio.

certifications / certificazioni



bulbs / lampadine

4 x 40W G9 Clear Halogen

feeding / alimentazione

230 / 120 V

dimensions / dimensioni

Ø 38 cm - H 48 cm

finishing / finitura

gloss powder coated
verniciatura a polveri lucida

colours / colori



white/orange

white/black

SAMA *table* /
GREGORIO SPINI / 2004



SAMA *table* /

GREGORIO SPINI / 2004

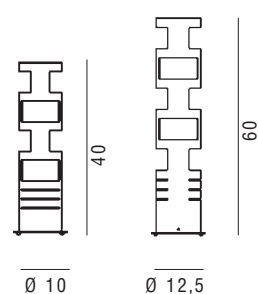

dimensions / dimensioni

S | Ø 10 cm - H 40 cm
M | Ø 12,5 cm - H 60 cm

finishing / finitura

gloss
lucida

colours / colori

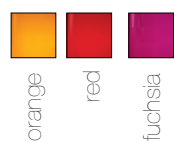

certifications / certificazioni



bulbs / lampadine

S | 1 x 50W GZ10
M | 1 x 50W GZ10

feeding / alimentazione

230 / 120 V

Table lamp with a two tone co-extruded laser cut Plexiglas diffuser and integrated reflector, fixed onto a white varnished steel base.

Lampada da tavolo con diffusore in Plexiglas bicolore coestruso tagliato a laser e riflettore incorporato, fissato su una base d'acciaio verniciato bianco.

Tischleuchte mit einem zweifarbig coextrudierten, lasergeschnittenen Plexiglasdiffuser und integriertem Reflektor, auf einer Weiss lackierten Basis befestigt.

Lampe de table avec un diffuseur en Plexiglas bicouleur co-extrudé et coupé laser et un réflecteur intégré, fixée à une base en acier couleur blanc.

Lámpara de mesa con difusor de Plexiglás bicolor co-extrudido y cortado con láser y reflector incorporado, fijada sobre una base de acero barnizado blanco.

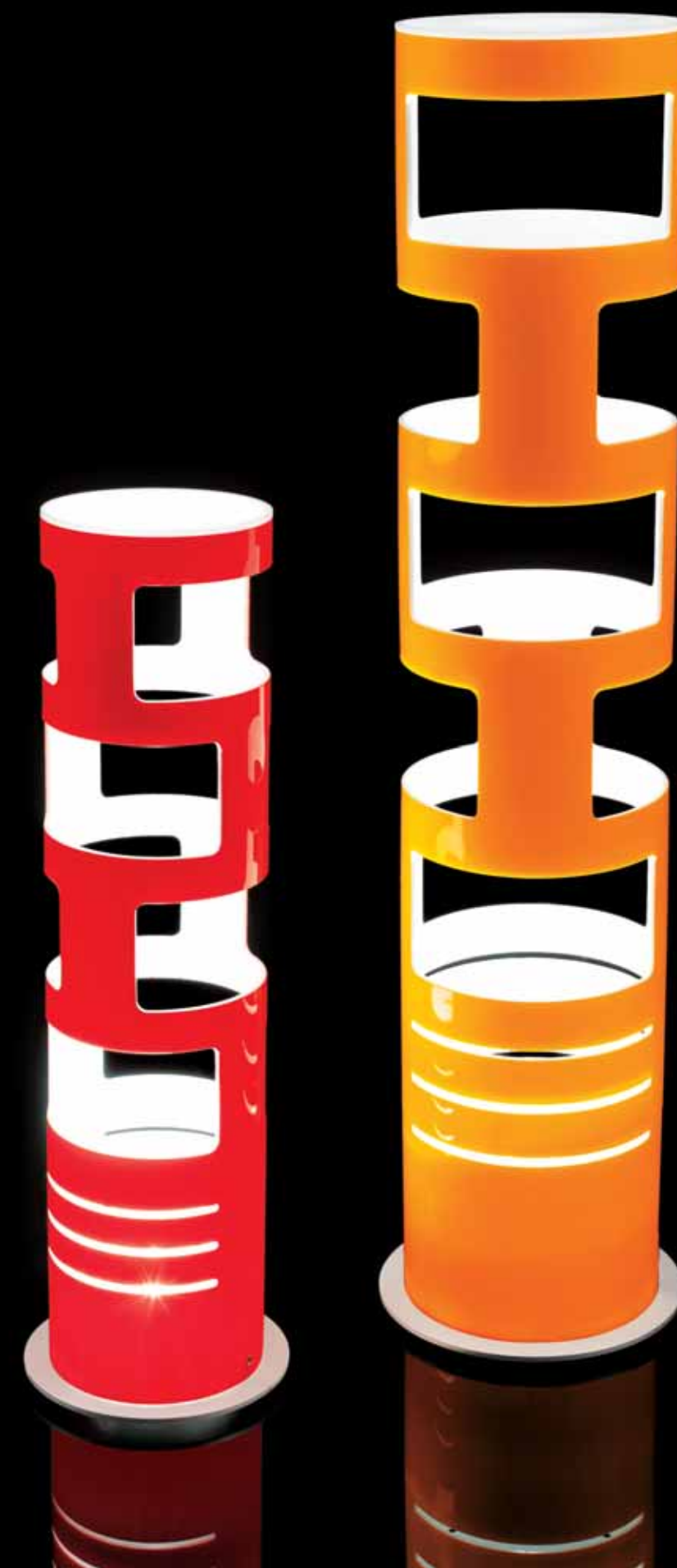

EERO *table* /
LUDOVICA & ROBERTO PALOMBA / 2000



EERO *table* /
LUDOVICA & ROBERTO PALOMBA / 2000

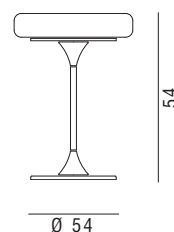

Table lamp, structure in white painted metal. Diffuser in mouth blown acid etched glass.

Lampada da tavolo, struttura in metallo verniciato bianco. Diffusore in vetro soffiato e acidato.

Tischleuchte, weiss lackierte Metallstruktur. Diffuser in mundgeblasenem und geätztem Glas.

Lampe de table, structure en métal verni blanc. Diffuseur en verre soufflé et acidé.

Lámpara de mesa, estructura de metal barnizado blanco. Difusor de vidrio soplado y acidado.

certifications / certificazioni

□ C € IP20

bulbs / lampadine

4 x 48W G9 Clear Halogen

feeding / alimentazione

230 / 120 V

dimensions / dimensioni

Ø 54 cm - H 54 cm

finishing / finitura

matt powder coated + acid etched glass
verniciatura a polveri opaca + vetro acidato

colours / colori



white

ALCHEMY

ARIK LEVY / 2001

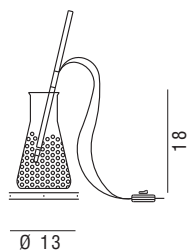

certifications / certificazioni

□ C E IP20

bulbs / lampadine

1 x 20W G4

feeding / alimentazione

230 / 120 V

dimensions / dimensioni

Ø13 cm - H 18 cm

finishing / finitura

gloss
lucida

colours / colori



glass

Table lamp, structure in satin nickel finished metal. Glass diffuser containing small glass spheres.

Lampada da tavolo, struttura in metallo nickel satinato. Diffusore in vetro trasparente contenente piccole sfere in vetro.

Tischleuchte, nickelsatinierte Metallstruktur. Diffuser in durchsichtigem Glas mit kleinen Glassphären.

Lampe de table, structure en métal satiné nickel. Diffuseur en verre transparent contenant des petites sphères en verre.

Lámpara de mesa, estructura de metal níquel satinado. Difusor de vidrio transparente que contiene en su interior pequeñas esferas de vidrio.



PADMA

MARZIO RUSCONI CLERICI / 2004

Table or floor lamp with three diffusers in white or two tone co-extruded and laser cut Plexiglas, base in transparent Plexiglas and reflector in aluminium.

Lampada da tavolo o da terra con tre diffusori in Plexiglas bianco o bicolore coestruso tagliato a laser, base in Plexiglas trasparente e riflettore in alluminio.

Tisch- oder Bodenleuchte aus drei lasergeschnittene, weiße oder zweifarbig coextrudierte Plexiglasdiffusers, mit Aluminiumreflektor und transparenter Plexiglas basis.

Lampe de table ou de terre avec trois diffuseurs en Plexiglas blanc ou bicouleur co-extrudé coupé laser, base en Plexiglas transparent et réflecteur en aluminium.

Lámpara de mesa o de pie con tres difusores de Plexiglas blanco o bicolor co-extrudido cortado con láser, base de Plexiglas transparente y reflector de aluminio.

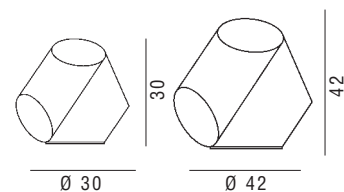

dimensions / dimensioni

PADMA | Ø 30 cm - H 30 cm
PADMA L | Ø 42 cm - H 42 cm

finishing / finitura

gloss
lucida

colours / colori

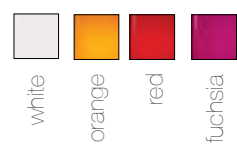

certifications / certificazioni



bulbs / lampadine

PADMA | 3 x 60W E14 (E12US)
Clear
PADMA L | 3 x 80W E27 (E26US)
Clear Tubular Halogen

feeding / alimentazione

230 / 120 V

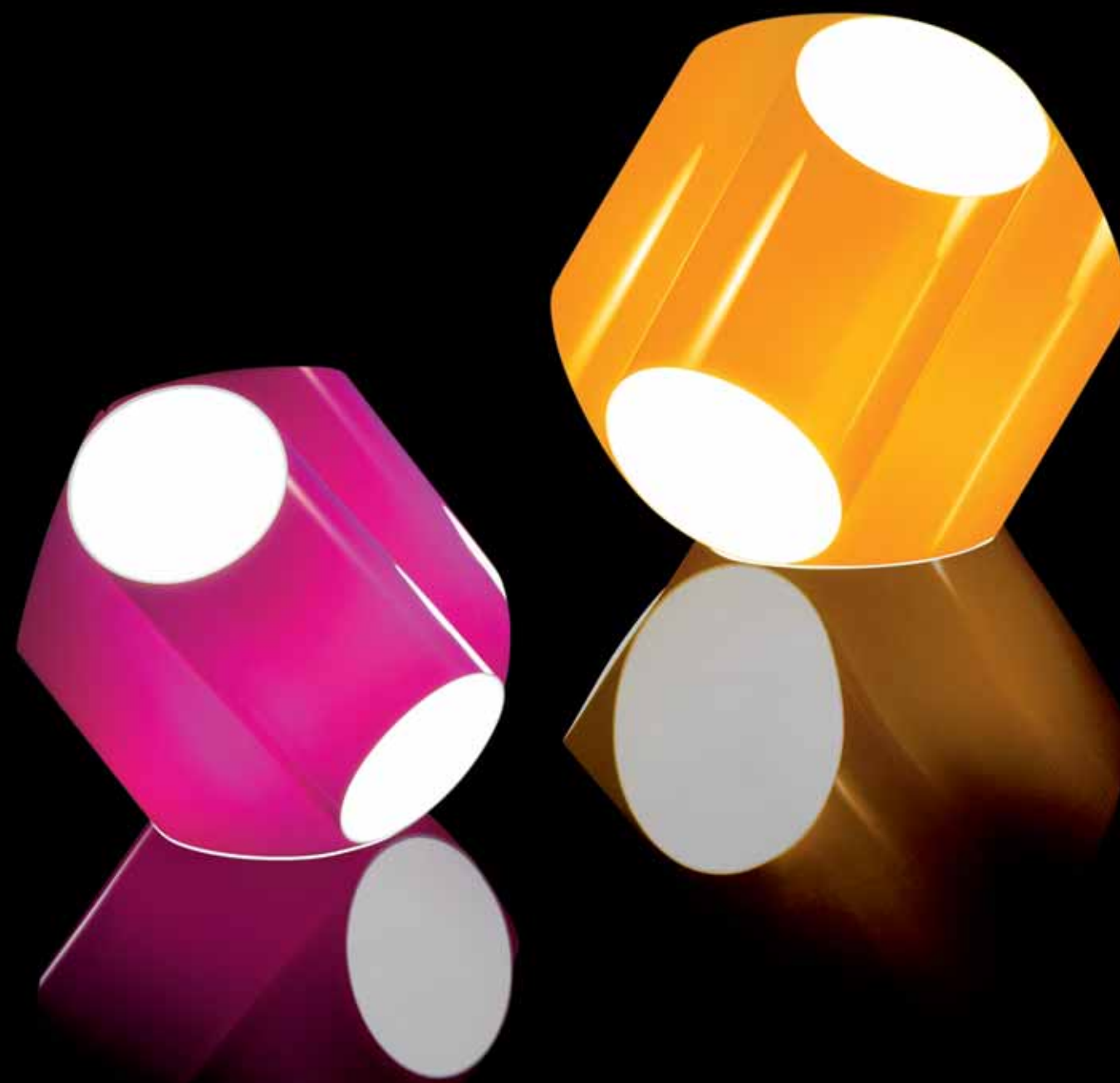

E.T.A. BABY

GUGLIELMO BERCHICCI / 1997



E.T.A. BABY

GUGLIELMO BERCHICCI / 1997

certifications / certificazioni

□ C E IP20

bulbs / lampadine

2 x 40W E14 (E12US)
Clear Olive

feeding / alimentazione

230 / 120 V

dimensions / dimensioni

L 34 cm - H 45 cm - W 25 cm



finishing / finitura

coloured fiberglass
vetroresina colorata

colours / colori

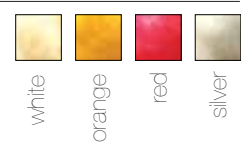

Table lamp. Handmade light diffuser in ecological fibre-glass, metallic inner structure (removable for bulbs changing), dimmer.

Lampada da tavolo. Corpo diffusore in vetroresina ecologica lavorato a mano, struttura interna in metallo (rimovibile per la sostituzione delle lampadine), dimmer.

Tischleuchte. Handgemachter Diffusor aus ökologischem Fiberglas, interne metallene Leuchtmittelhalterung (herausnehmbar um Leuchtmittel auszuwechseln), Dimmer.

Lampe de table. Diffuseur en fibre de verre écologique fait à la main, structure intérieure en métal (déplaçable pour changer les ampoules), variateur de lumière.

Lámpara de mesa. Cuerpo difusor de resina de vidrio ecológica trabajado a mano, estructura interna de metal (extraíble para poder sustituir las bombillas), dimmer.



MIRAGE
L.LONGO - DE-SIGNUM / 2008



MIRAGE

L.LONGO - DE-SIGNUM / 2008

certifications / certificazioni

□ C E IP20

bulbs / lampadine

2 x 6W T5 Fluor

feeding / alimentazione

230 / 120 V

dimensions / dimensioni

L 24,5 cm - H 28 cm - W 12,5 cm

finishing / finitura

matt powder coated
verniciatura a polveri opaca

colours / colori



white



black



fuchsia

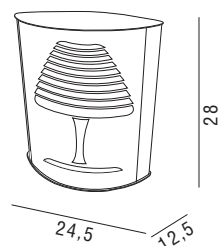

Fluorescent table lamp with holographic effect on the front diffuser and opal diffuser on the back side. Powder coated metal structure.

Lampada da tavolo fluorescente con diffusore anteriore ad effetto olografico e diffusore posteriore opale. Struttura portante in metallo verniciato.

Tischleuchte mit Leuchtstoffröhren. Vorderseite mit holographischem Effekt und Rückseite mit opalweißem Diffusor. Lackierte Metallstruktur.

Lampe de table fluorescente composé d'un diffuseur frontal avec un effet holographique et d'un diffuseur opalin à l'arrière. Structure en métal vernis.

Lámpara de mesa fluorescente con difusor anterior con efecto holográfico y difusor posterior ópalo. Estructura portante de metal pintado.



TRIPOD *table /*

CHRISTOPHE PILLET / 2002

Table lamp, structure in grey or white painted metal. Shade in fire resistant fabric closed by an anodized perforated aluminium disc.

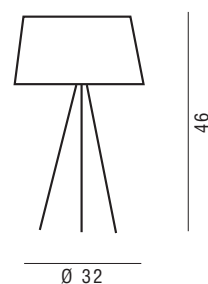

Lampada da tavolo, struttura in metallo verniciato grigio o bianco. Paralume in tessuto ignifugo chiuso da disco in alluminio microforato e anodizzato.

Tischleuchte, grau oder weiss lackierte Metallstruktur. Diffuser in feuerfestem Stoff, von durchlöcherter eloxierter Aluminiumscheibe verschlossen.

Lampe de table, structure en métal verni gris ou blanc. Diffuseur en tissu ignifuge fermé par un disque en aluminium micropercé anodisé.

Lámpara de mesa, estructura de metal barnizado gris o blanco. Pantalla de tejido ignifugo fijada con disco de aluminio microperforado y anodizado.

certifications / certificazioni

IP20

bulbs / lampadine

3 x 40W E14 (E12US) Clear

feeding / alimentazione

230 / 120 V

dimensions / dimensioni

Ø 32 cm - H 46 cm

finishing / finitura

painted metal + fabric
metallo verniciato + tessuto

colours / colori

white
 ecru
 moka



CLOVER

BRODIE NEILL / 2011



CLOVER

BRODIE NEILL / 2011

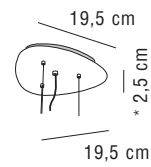

* canopy / rosone
white / bianco

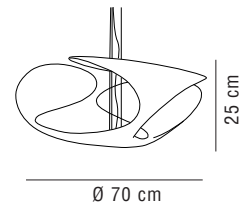

certifications / certificazioni

⊕ CE IP20

bulbs / lampadine

2 x max 205 W B15D
METAL HALIDE | 1 x 70W G8.5

feeding / alimentazione

230 / 120 V

dimensions / dimensioni

Ø 70 cm - H 25 cm
* METAL HALIDE CANOPY | H 5 cm

finishing / finitura

matt liquid varnished
verniciatura a liquido opaca

colours / colori



white

Suspension lamp. Moulded polyurethane matt varnished body, aluminium reflector. Metal halide version available.

Lampada a sospensione. Corpo in poliuretano stampato verniciato opaco, riflettore in alluminio. Disponibile nella versione a ioduri metallici.

Pendelleuchte. Körper aus matt lackiertem und gus-formiertem Polyurethan, Aluminiumreflektor. Version aus metallischen Jodiden verfügbar.

Lampe à suspension. Corps en polyuréthane moulée vernis mat, réflecteur en aluminium. Version disponible métal halogène.

Lámpara de suspensión. Estructura en poliuretano pintado mate, reflector en aluminio. Disponible en la versión de halogenuro metálico.

TREIS

BENJAMIN HUBERT / 2011



TREIS

BENJAMIN HUBERT / 2011

* canopy / rosone
warm white / bianco
grey / grigio
brown / marrone

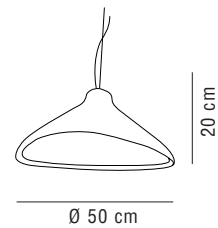

Suspension lamp. Deep drawn gloss varnished metal body, texturized diffuser.

Lampada a sospensione. Corpo in metallo imbutito verniciato lucido, diffusore texturizzato.

Pendelleuchte. Körper aus glanz lackiertem tiefgezogenem Metall, ausgeschnittenem Diffusor.

Lampe à suspension. Corps en métal découpé vernis brillant, diffuseur texturé.

Lámpara de suspensión. Estructura metálica pintada brillo, difusor en metracrilato texturizado.

certifications / certificazioni

⊕ C E IP20

dimensions / dimensioni

Ø 50 cm - H 20 cm

bulbs / lampadine

3 x max 12W E14 (E12US) Fluor

finishing / finitura

gloss powder coated
verniciatura a polveri lucida

feeding / alimentazione

230 / 120 V

colours / colori

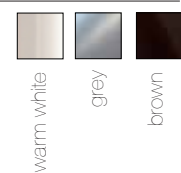

SPILLO *ceiling* /
CONSTANTIN WORTMANN / 2010



SPILLO *ceiling* /

CONSTANTIN WORTMANN / 2010

Indoor and outdoor ceiling lamp. Rotational-moulded polyethylene diffuser. Canopy in the indoor version, wiring with IP65 connection device in the outdoor version.

Lampada a sospensione per interni ed esterni. Diffusore in polietilene stampato in rotazionale. Rosone nella versione da interni, cavo elettrico con dispositivo di connessione IP65 nella versione da esterni.

Pendelleuchte für Außen und Innen. Mit Polyethylen-diffuser in Rotomoulding. Deckenleuchte für den Innenbereich auch für den Außenbereich geeignet in der Ausführung mit elektrischem Kabel und Verbindungseinheit IP65.

Suspension pour intérieurs et extérieurs. Diffuseur en polyéthylène moulé par rotation. Rosace dans la version pour intérieur, câble électrique avec dispositif de connexion IP65 dans la version pour extérieur.

Lámpara colgante. Difusor de polietileno estampado en rotacional. Florón en la versión para interiores, cable eléctrico con dispositivo de conexión IP65 en la versión para exteriores.

★ indoor version only

* canopy / rosone
white / bianco

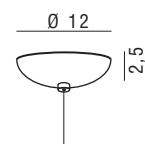

certifications / certificazioni

⊕ C E IP20 or IP65

bulbs / lampadine

1 x 21 W E27 (E26US) Fluo

feeding / alimentazione

230 / 120 V

dimensions / dimensioni

Ø 18 cm - H 67 cm

finishing / finitura

gloss powder coated
verniciatura lucida a polveri

colours / colori



white

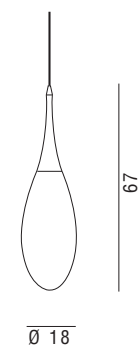

DEW

EMMANUEL BABLED / 2009



DEW

EMMANUEL BABLED / 2009

Suspension lamp with glass diffuser and die casted aluminium heat sink. High Voltage Power Led. It can be realized on demand as a multiple pendant chandelier.

Lampada a sospensione con diffusore in vetro e dissipatore in alluminio pressofuso. Led di potenza a tensione di rete. Il prodotto si presta a composizioni multiple realizzabili a richiesta.

Pendelleuchte mit massiver Glaskugel und einem integriertem Aluminiumelement, Hochvol-LED. Auf Anfrage fertigen wir Dew mit einer Vielzahl von Glaskugeln nach Ihren individuellen Vorgaben.

Suspension avec un diffuseur en verre et dissipateur en aluminium moulé sous pression. Led de puissance à haut voltage. Le produit peut être réalisé, sur demande, comme une composition avec plusieurs pendentif.

Lámpara colgante con difusor de vidrio y disipador de aluminio vaciado a presión. Led de potencia de tensión de red. El producto se presta para composiciones múltiples realizables a petición del cliente.

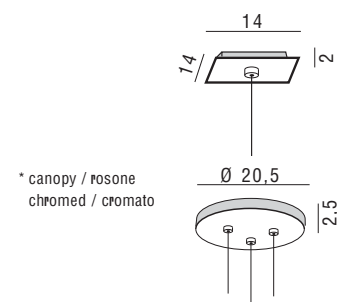

* canopy / rosone
chromed / cromato

certifications / certificazioni

CE IP20

bulbs / lampadine

DEW | 1 x 4W Power Led
DEW3 | 3 x 4W Power Led

feeding / alimentazione

230 / 120 V

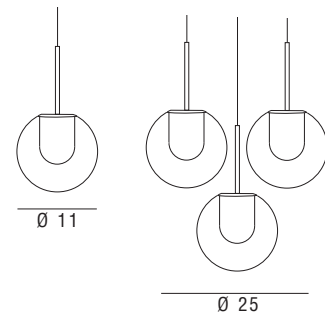

dimensions / dimensioni

DEW | Ø 11 cm
DEW 3 | Ø 25 cm

finishing / finitura

gloss glass + chromed structure
vetro lucido + struttura cromata

colours / colori



transp.

GINA ceiling /

L.LONGO & A.ROMANO - DE-SIGNUM / 2009



GINA *ceiling* /
L.LONGO & A.ROMANO - DE-SIGNUM / 2009

* canopy / rosone
white / bianco

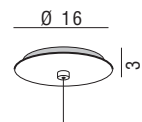

certifications / certificazioni

⊕ C E IP20

bulbs / lampadine

3 x 21 W E27 (E26US) Fluor

feeding / alimentazione

230 / 120 V

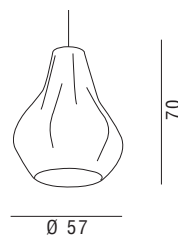

dimensions / dimensioni

Ø 57 cm - H 70 cm

finishing / finitura

vinyl-covered fabric
tessuto spalmato

colours / colori

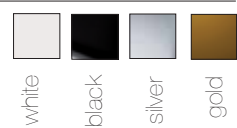

Suspension lamp. Elasticized vinyl-covered fabric, cloth-covered metal structure.

Lampada a sospensione. Struttura in metallo rivestita in tessuto spalmato elasticizzato.

Pendelleuchte mit vinyl beschichtete Gewebe auf Metallrahmen.

Lampe à suspension. Structure en métal recouverte de tissu enduit élastique.

Lámpara colgante. Estructura de metal recubierta de tejido untado elástico.



ABYSS ceiling /
OSKO+DEICHMANN / 2007



ABYSS ceiling /

OSKO+DEICHMANN / 2007

Suspension lamp with high voltage Led strip and modular structure in injection moulded opal polycarbonate, attached to white Plexiglas tube with fluorescent spotlight.

Lampada a sospensione con filo di Led a tensione di rete e struttura modulare portante in policarbonato opalino stampato a iniezione, fissata a tubo in Plexiglas bianco con spot fluorescente.

Hängeleuchte mit Hochvolt Led Streifen und Modularstruktur aus opalem Polycarbonat in Spritzgussform, fixiert an Plexiglasröhre mit fluoreszente Spotlicht.

Lampe à suspension avec un fil de Led à haute voltage et structure modulaire portante en polycarbonate opale moulé à injection, fixé au tube en Plexiglas avec une lumière fluorescente directionnelle.

Lámpara colgante con cable de Led de tensión de red y estructura modular portante de policarbonato opalino estampado a inyección, fijada a un tubo de Plexiglas blanco con spot fluorescente.

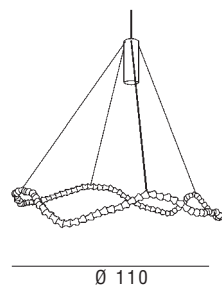

* canopy / rosone
white / bianco

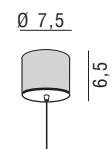

certifications / certificazioni

⊕ ⊞ IP20

bulbs / lampadine

1 x 10W LED Strip
1 x 15W E27 (E26US)
Fluorescent Spot

feeding / alimentazione

230 / 120 V

dimensions / dimensioni

Ø 110 cm

finishing / finitura

gloss
lucida

colours / colori



white

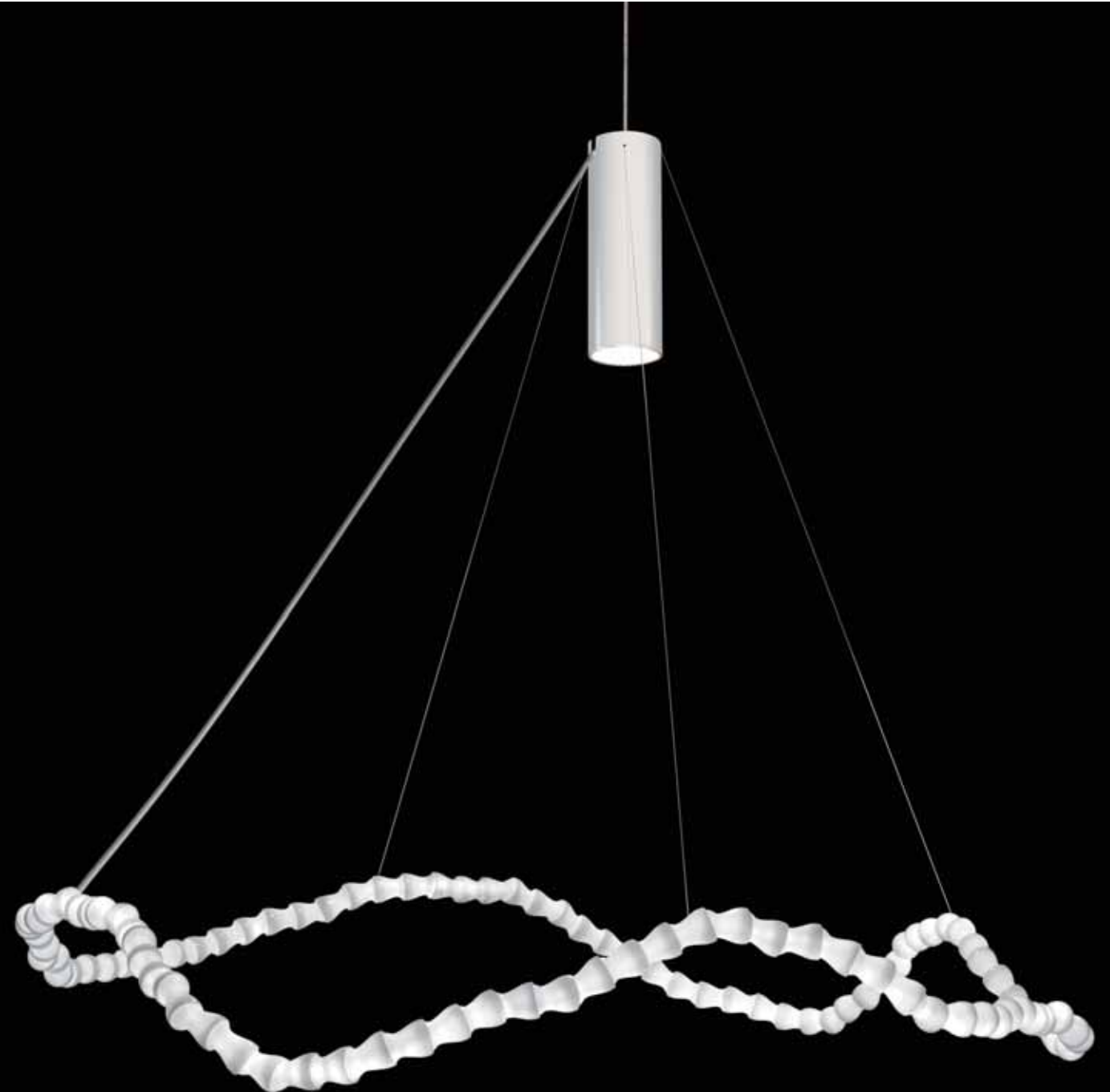

ATOMIUM *ceiling* /
HOPF&WORTMANN - BÜRO FÜR FORM / 2006



ATOMIUM *ceiling* /

HOPF&WORTMANN - BÜRO FÜR FORM / 2006

Suspension lamp with rotational-moulded polyethylene diffuser and inner structure with six light sources fixed on steel coil springs. Self-clinching supply cable with inserted steel wire.

Lampada a sospensione con diffusore in polietilene stampato in rotazionale con struttura interna a sei luci montate su molle tensionate in acciaio. Cavo autoportante con anima in acciaio.

Hängeleuchte mit Polyethylen diffuser in Rotomoulding, innen Federstruktur aus Stahl mit sechs Lampen. Kabel mit innenliegendem Stahldraht.

Lampe à suspension avec un diffuseur en polyéthylène imprimé en rotoroulage et une structure intérieure à six luminaires placées sur des ressorts tensionnés en acier. Câble autoportant avec une âme en acier.

Lámpara colgante con difusor de polietileno estampado en rotacional con estructura interna de seis luces montadas sobre resortes tensados de acero. Cable autoportante con alma de acero.

* canopy / rosone
white / bianco

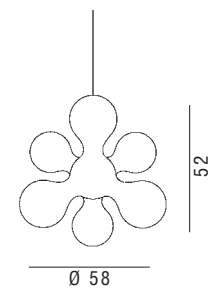
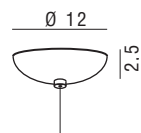

certifications / certificazioni

CE IP20

bulbs / lampadine

6 x 40W E14 (E12US) Clear
OR 6 x 12W E14 (E12US) Fluo

feeding / alimentazione

230 / 120 V

dimensions / dimensioni

Ø 58 cm - H 52 cm

finishing / finitura

gloss
lucida

colours / colori



white

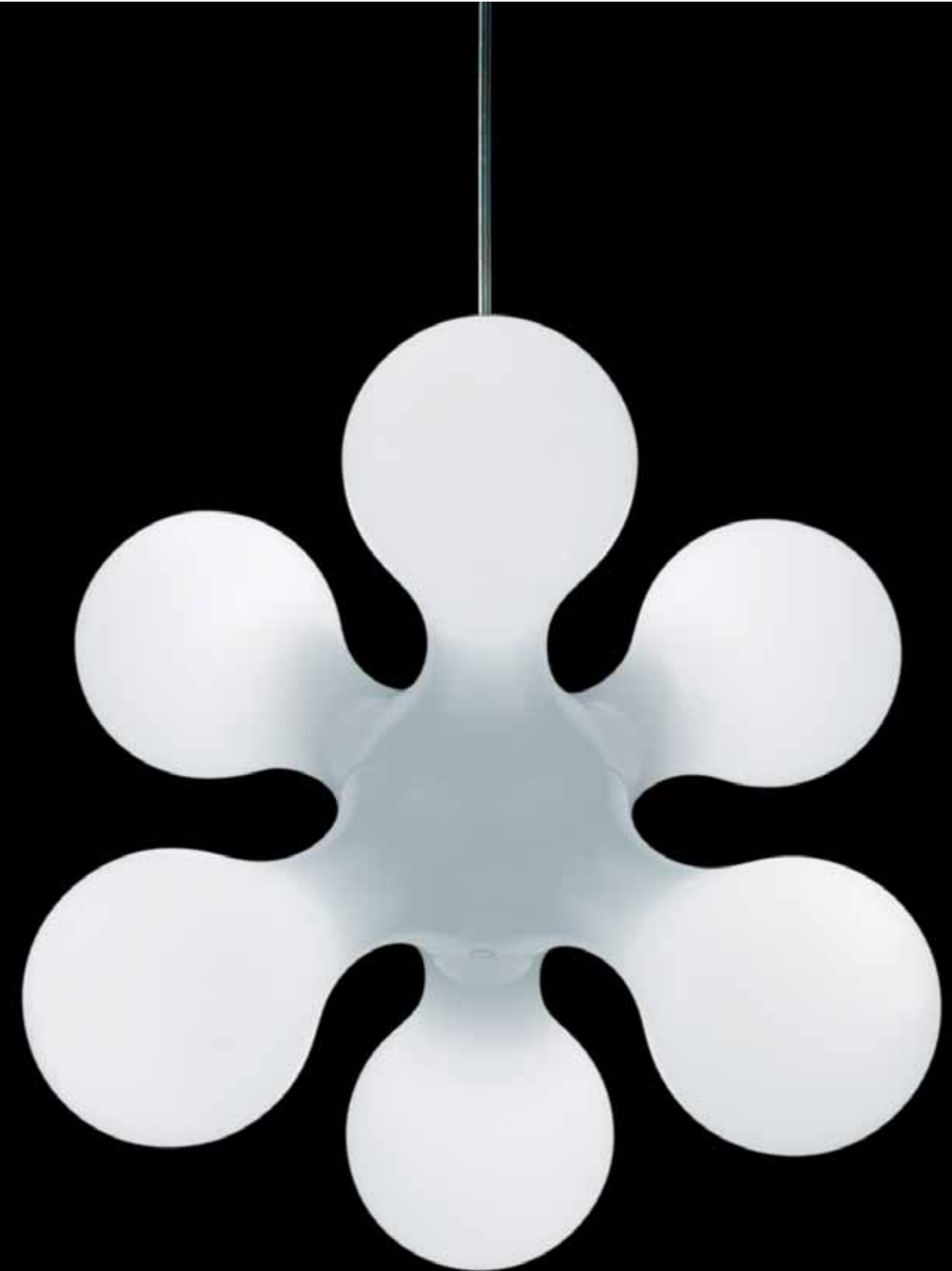

BOLIDO
MARCO VALENTE / 2007



BOLIDO

MARCO VALENTE / 2007

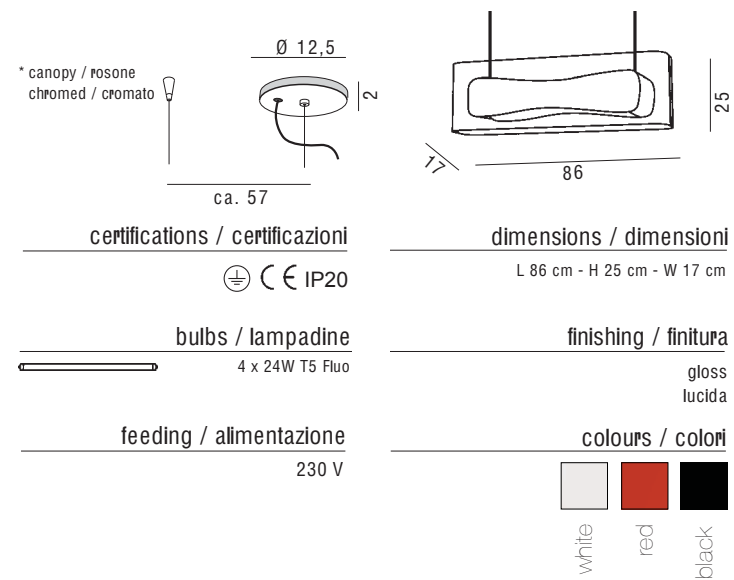

Suspension lamp in Plexiglas. Supporting metal structure with two white Plexiglas diffusers.

Lampada a sospensione in Plexiglas. Struttura portante in metallo con due diffusori in Plexiglas opalino.

Pendelleuchte aus Plexiglas. Tragende Metallstruktur mit zwei weißen Plexiglasdiffusern.

Lampe à suspension en Plexiglas. Structure portante en metal avec deux diffuseurs en Plexiglas opale.

Lámpara colgante de Plexiglas. Estructura portante de metal con dos difusores de Plexiglas opalino.



HONEYMOON *ceiling* /
JOHN SEBASTIAN / 2007



HONEYMOON *ceiling* /

JOHN SEBASTIAN / 2007

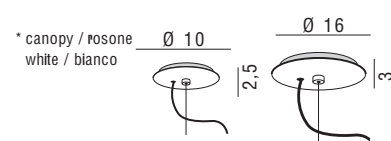

certifications / certificazioni



bulbs / lampadine

S | 1 x 33W G9 Clear Halogen
L | 1 x 80W E27 (E26US)
Clear Tubular Halogen

feeding / alimentazione

230 / 120 V

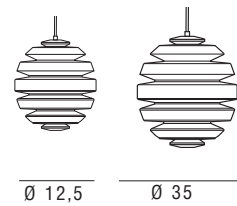

dimensions / dimensioni

S | Ø 12,5 cm
L | Ø 35 cm

finishing / finitura

gloss
lucida

colours / colori



white

Suspension lamp with opal mouth blown triplex glass diffuser. Fixture in spun opaque white varnished metal.

Lampada a sospensione con diffusore in vetro opale incamiciato e soffiato. Struttura in metallo tornito verniciato bianco opaco.

Hängeleuchte mit Leuchtkörper aus mundgeblasenem, opalem Triplexglas. Metallhalterung in mattem weiß lackiert.

Lampe à suspension au diffuseur en verre opale soufflé triplex. Structure en métal verni blanc opaque.

Lámpara colgante con difusor de vidrio ópalo enfundado y soplado. Estructura de metal torneado barnizado blanco opaco.

* Honeymoon ceiling small excluded



LOUP-O

A+A COOREN / 2007



LOUP-O

A+A COOREN / 2007

* canopy / rosone
white / bianco

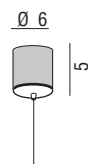

certifications / certificazioni

⊕ CE IP20

bulbs / lampadine

1 x 50W GU

feeding / alimentazione

230 / 120 V

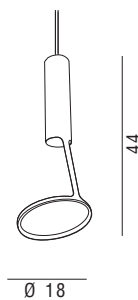

dimensions / dimensioni

Ø 18 cm - H 44 cm

finishing / finitura

matt powder coated
verniciatura a polveri opaca

colours / colori

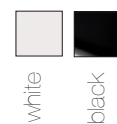

white

black

Suspension lamp with direct and indirect spotlight. Spun and laser cut metal structure with opaque varnish in black or white. Mirrored glass diffuser for partial light reflexion.

Lampada a sospensione a luce diretta e indiretta. Struttura in metallo tornito e tagliato a laser con verniciatura opaca bianca o nera. Diffusore in vetro semi specchiante per riflessione parziale della luce.

Hängeleuchte mit direktem und indirektem Spotlicht. Lasergeschnittene und matt lackierte Metallstruktur in weiß oder schwarz.

Lampe à suspension avec lumière spot direct et indirect. Structure en métal coupé laser e verni opaque blanche ou noir. Diffuseur miroir pour réflexion partielle de la lumière.

Lámpara colgante de luz directa e indirecta. Estructura de metal torneado y cortado con láser, barnizada opaca blanca o negra. Difusor de vidrio con acabado semi-espejo para la reflexión parcial de la luz.



ENTROPIA *ceiling* /

LIONEL DEAN / 2007

* canopy / rosone
chromed / cromato

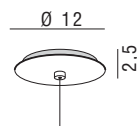

certifications / certificazioni

⊕ CE IP20

bulbs / lampadine

1 x 25W G9 Clear Halogen

feeding / alimentazione

230 / 120 V

dimensions / dimensioni

Ø 12 cm

finishing / finitura

matt diffuser + chromed base
diffusore opaco + base cromata

colours / colori



white

Suspension lamp with diffuser in laser-sintered nylon built in 1200 layers. Chrome-plated metal fixture.

Lampada a sospensione con diffusore in nylon sinterizzato al laser in 1200 strati. Particolari in metallo cromato.

Hängeleuchte mit, in 1200 Schichten, lasergesintertem Nylondiffuser. Verchromte Metallteile.

Lampe à suspension avec un diffuseur en nylon procédé au frittage laser en 1200 couches. Détails en métal chromé.

Lámpara colgante con difusor de nylon sinterizado al láser en 1200 capas. Detalles en metal cromado.



PLUTO ceiling /
PAOLA NAVONE / 2006



PLUTO *ceiling* /

PAOLA NAVONE / 2006

Suspension lamp with out of mould mouth-blown diffuser, rotationally-formed and internally sand-blasted. This artistic craftwork makes any and each product unique. This irregularly shaped glass is assembled on chrome-plated metal fixtures through an harmonic steel crown spring. Silicon supply cable with intertwined poles.

Lampada a sospensione con diffusore in vetro soffiato a spessore fuori stampo, lavorato in rotazione e internamente sabbato. Questa lavorazione artistica rende unico ogni singolo prodotto. Il vetro dalla forma irregolare è fissato a particolari metallici cromati tramite una molla di acciaio armonico a corona. Alimentazione con cavo in silicone a poli intrecciati.

Hängeleuchte aus mundgeblasenem Glasdiffuser, in Rotation handverarbeitet, innen satiniert. Diese Fertigung macht jedes Glas einzigartig. Verchromte Metallstruktur mit innenliegender Stahlfeder. Silikonkabel gewebt.

Lampe à suspension avec un diffuseur en verre soufflé à épaisseur hors de moule, ouvert en rotation et internement sablé. Cet ouvrage artistique rend unique chaque produit. Le verre, dont la forme est irrégulière, est fixé à des détails en métal chromé à travers un ressort à couronne en acier harmonique. Alimentation avec câble en silicone à pôles tressés.

Lámpara colgante con difusor de vidrio soplado hasta espesor fuera del molde, trabajado en rotación y arenado en su interior. Esta elaboración artística hace que cada pieza sea única. El vidrio de forma irregular está fijado a soportes de metal cromado mediante un resorte de corona de acero armónico. Alimentación con cable de silicona de polos entrelazados.



* canopy / rosone
chromed / cromato

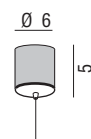

certifications / certificazioni



bulbs / lampadine

1 x 40W G9 Clear Halogen

feeding / alimentazione

230 / 120 V

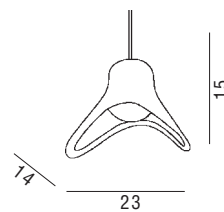

dimensions / dimensioni

L 23 cm - H 15 cm - W 14 cm

finishing / finitura

gloss
lucida

colours / colori



transp.

BOKKA ceiling /

KARIM RASHID / 2005

* canopy / rosone
chromed / cromato

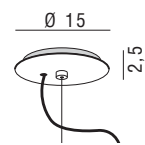

certifications / certificazioni



bulbs / lampadine

1 x 120W E27 (E26US)
Clear Tubular Halogen

feeding / alimentazione

230 / 120 V

dimensions / dimensioni

Ø 38 cm - H 54 cm

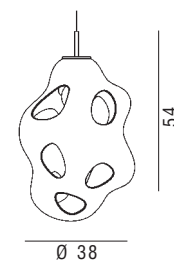

finishing / finitura

gloss
lucida

colours / colori

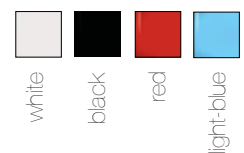

Suspension lamp with triplex glass diffuser, mouth blown and water jet cut. Chromed metal fixture.

Lampada a sospensione con diffusore in vetro incamiciato, soffiato e forato a getto d'acqua. Particolari in metallo cromato.

Hängeleuchte mit Leuchtkörper aus mundgeblasenem und Wasserstrahl geschnittenem Triplexglas. Verchromte Metallhalterung.

Lampe à suspension au diffuseur en verre soufflé triplex et troué à jet d'eau. Détails en acier chromé.

Lámpara colgante con difusor de vidrio enfundado, soplado y perforado con chorro de agua. Detalles de metal cromado.



FLOOB ceiling /

KARIM RASHID / 2007

* canopy / rosone
white / bianco
orange / arancione
fuchsia / fucsia

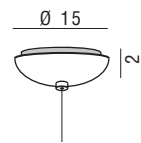

certifications / certificazioni

⊕ CE IP20

bulbs / lampadine

1 x 23W E27 (E26US)
PAR38 Fluo

feeding / alimentazione

230 / 120 V

dimensions / dimensioni

Ø 45 cm - H 60 cm

finishing / finitura

gloss
lucida

colours / colori

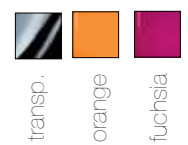

Suspension downlighter in thermoformed and extruded Plexiglas with spun and laser cut aluminium reflector and integrated acid etched glass diffuser.

Lampada a sospensione a luce diretta in Plexiglas termoformato ed estruso con riflettore in alluminio tornito e tagliato al laser e diffusore in vetro acidato.

Hängeleuchte mit direktem Licht aus thermogeformtem und extrudiertem Plexiglas. Reflektor aus lasergeschnittenem Aluminium mit geätztem Glasdiffuser.

Lampe à suspension avec lumière direct en Plexiglas thermoformé et extrudé. Réflecteur en aluminium repoussé et coupé laser avec diffuseur en verre acidé.

Lámpara colgante de luz directa de Plexiglás termoformado y extrudido con reflector de aluminio torneado y cortado con láser y difusor de vidrio acidado.





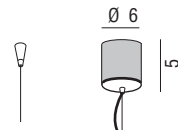

SHAKTI AIR

MARZIO RUSCONI CLERICI / 2002







* canopy / rosone
white / blanco



certifications / certificazioni

    IP20
with canopy > Class 1
with plug > Class 2

bulbs / lampadine

	200 6 x 80W E27 (E26US) Clear Tubular Halogen
	OR 6 x 21W E27 (E26US) Fluo
	250 6 x 80W E27 (E26US) Clear Tubular Halogen
	OR 6 x 25W E27 (E26US) Fluo
	320 6 x 80W E27 (E26US) Clear Tubular Halogen
	OR 6 x 25W E27 (E26US) Fluo

feeding / alimentazione

230 / 120 V

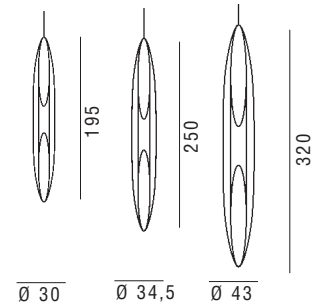

dimensions / dimensioni

200 | Ø 30 cm - H 195 cm
250 | Ø 34,5 cm - H 250 cm
320 | Ø 43 cm - H 320 cm

finishing / finitura

gloss
lucida

colours / colori

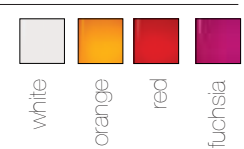

Suspension lamp, made of three Plexiglas laser cut diffusers, electrified with cable dimmer and plug or with ceiling fixture.

Lampada a sospensione dimmerabile composta da tre diffusori in Plexiglas tagliati a laser, elettrificati con cavo e spina a terra o con rosone a soffitto.

Dimmbare Hängeleuchte mit Kabel und Stecker, die aus drei lasergeschnittene Plexiglasdiffuser besteht. Deckenleuchteversion erhältlich.

Lampe à suspension dimmerable composée de trois diffuseurs en Plexiglas coupés laser, électrifiés par un câble et une prise de terre ou à plafond.

Lámpara colgante con dimmer, compuesta por tres difusores de Plexiglas cortados con láser, electrificados con cable y enchufe o con florón a techo.

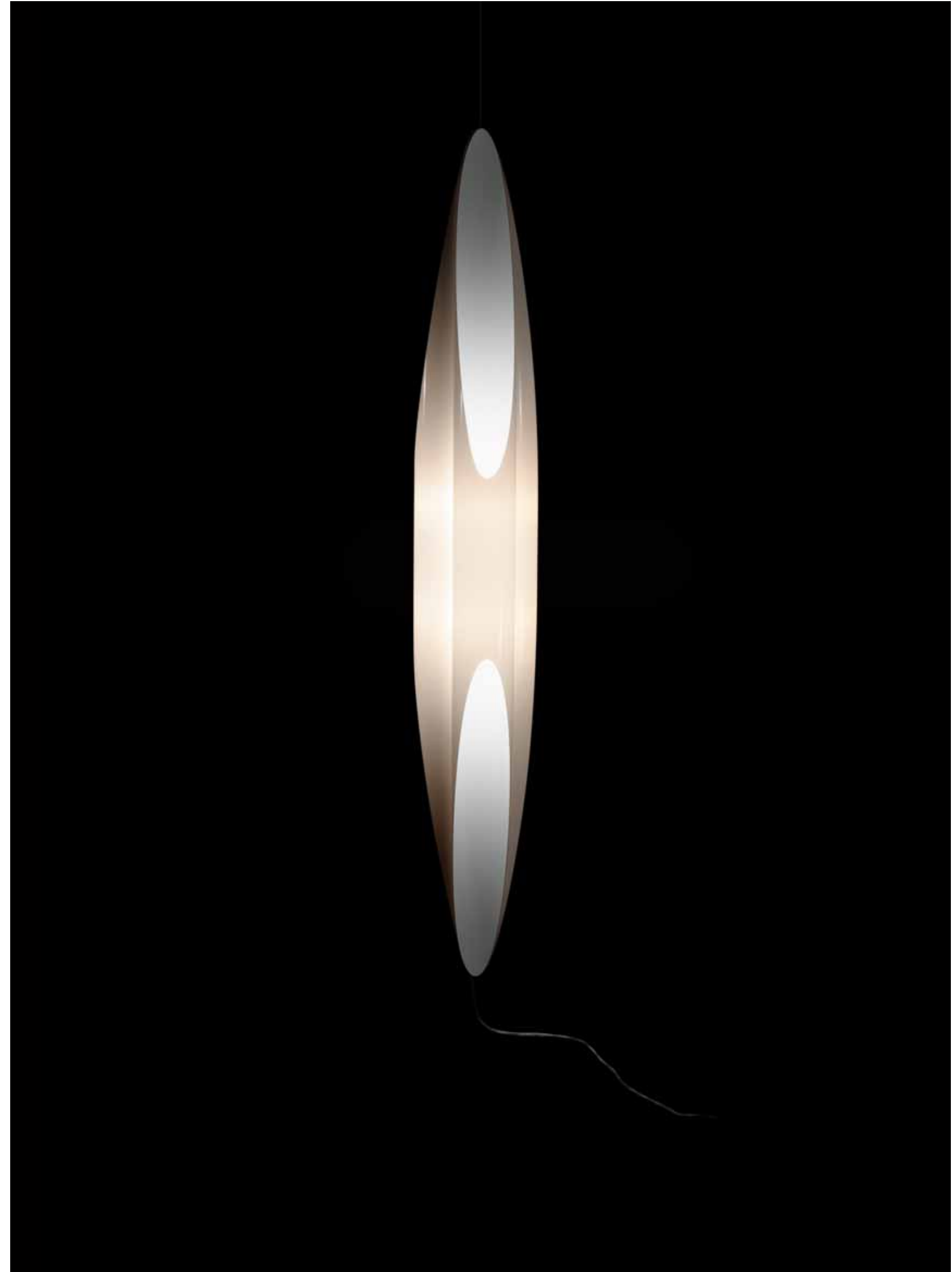

SHAKTI SKY

MARZIO RUSCONI CLERICI / 2003



SHAKTI SKY

MARZIO RUSCONI CLERICI / 2003

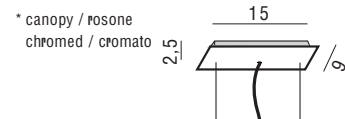

certifications / certificazioni

CE IP20

bulbs / lampadine

200 | 2 x 20W E27 (E26US)
PAR38 Fluo

250 | 2 x 23W E27 (E26US)
PAR38 Fluo

320 | 2 x 23W E27 (E26US)
PAR38 Fluo

feeding / alimentazione

230 / 120 V

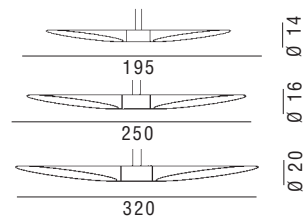

dimensions / dimensioni

200 | Ø 14 cm - H 195 cm
250 | Ø 16 cm - H 250 cm
320 | Ø 20 cm - H 320 cm

finishing / finitura

gloss
lucida

colours / colori

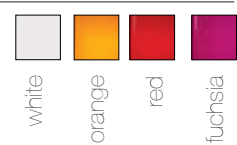

Suspended lamp with diffusers in laser cut Plexiglas, inserted in a polished steel ring.

Lampada a sospensione con diffusori in Plexiglas tagliati a laser, inseriti in un anello in acciaio a specchio.

Pendelleuchte mit zwei lasergeschnittenen Plexiglas-diffuser, die in einem polierten Edelstahlring befestigt werden.

Lampe à suspension avec des diffuseurs en Plexiglas coupés laser, introduits dans un corps central en acier à miroir.

Lámpara colgante con difusores de Plexiglas cortados con láser, introducidos en un anillo de acero acabado a espejo.

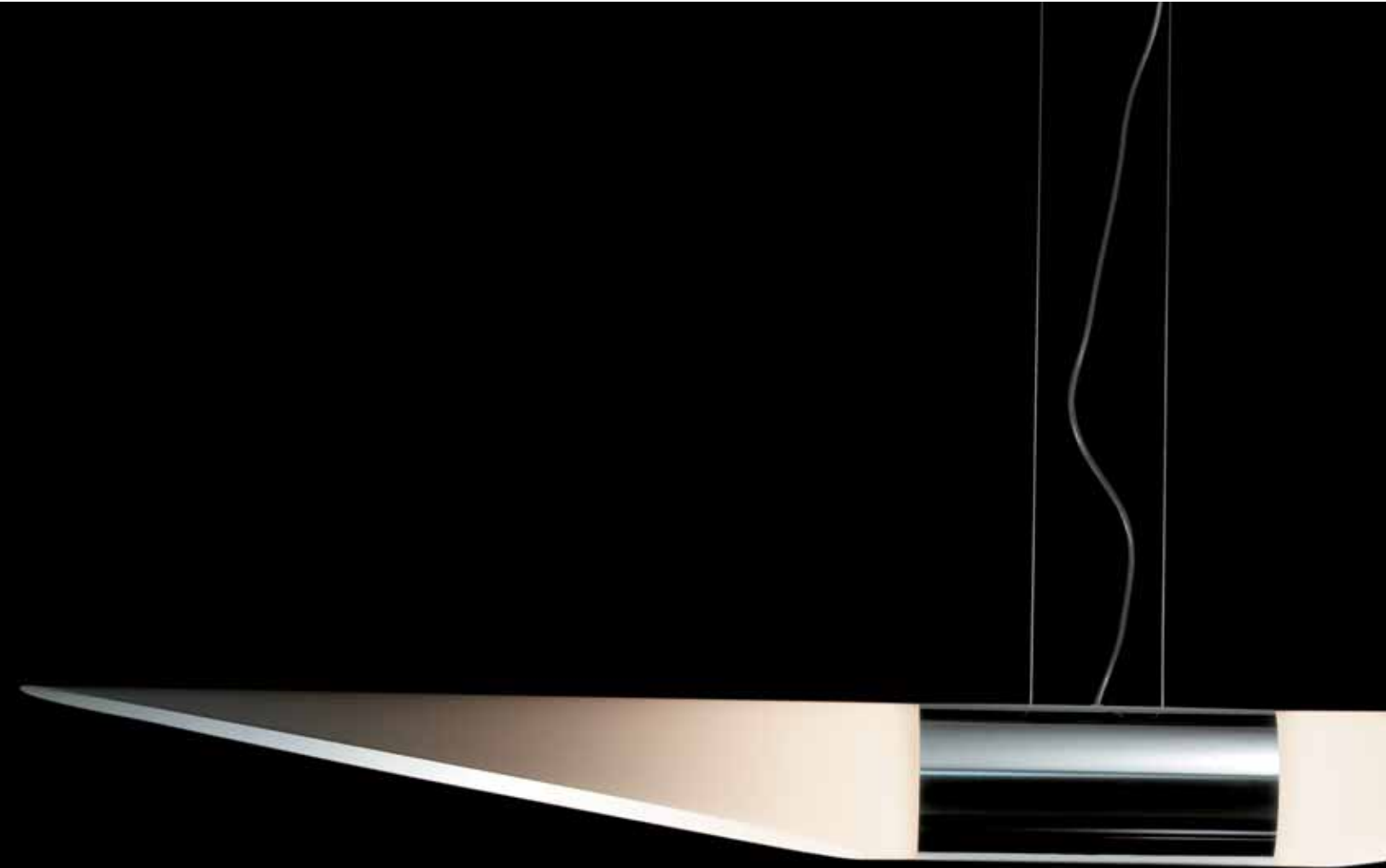

NOGLOBE *ceiling* /
LAURA AGNOLETTO | MARZIO RUSCONI CLERICI / 2004



NOGLOBE *ceiling* /

LAURA AGNOLETTO | MARZIO RUSCONI CLERICI / 2004

Ceiling lamp, made of a white acrylic sphere with three elliptic laser cut holes and chromed metal structure. Functionally, Noglobe spreads an ambience light, soft as well as directional.

Lampada a sospensione, costituita da una sfera in acrilico bianco con tre fori ellissoidali tagliati a laser e struttura in acciaio tornito e cromato. Dal punto di vista funzionale, Noglobe emana una luce diffusa morbida e al tempo stesso direzionale.

Hängeleuchte, die aus einer weißen Plexiglassphäre mit drei elliptischen Laserausschnitten besteht, montiert auf eine verkromte Stahlstruktur. Noglobe strahlt ein weiches und gleichzeitig direktes Licht aus.

Lampe à suspension constituée par une sphère en acrylique blanc avec trois ronds à la forme d'une ellipse coupée laser et structure en acier repoussé et chromé. Au niveau fonctionnel, Noglobe émane une lumière diffusée à la fois douce et directionnelle.

Lámpara colgante, constituida por una esfera de acrílico blanco con tres orificios elipsoidales cortados con láser y estructura de acero torneado y cromado. Desde el punto de vista funcional, Noglobe emana una luz difusa suave y al mismo tiempo direccional.

* canopy / rosone
chromed / cromato

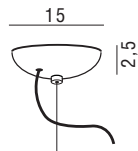

certifications / certificazioni

⊕ CE IP20

bulbs / lampadine

- 35 | 1 x 21W E27 (E26US)
Globo Fluorescent diam. 102mm
- 50 | 1 x 25W E27 (E26US)
Globo Fluorescent diam. 120mm
- 60 | 3 x 25W E27 (E26US)
Globo Fluorescent diam. 120mm

feeding / alimentazione

230 / 120 V

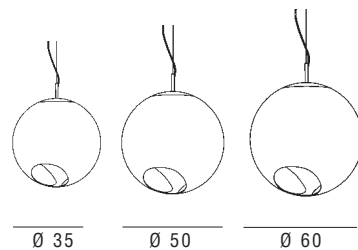

dimensions / dimensioni

35 | Ø 35 cm
50 | Ø 50 cm
60 | Ø 60 cm

finishing / finitura

gloss
lucida

colours / colori

white



TORIC ceiling /
PATRICK NORGUET / 2003



TORIC *ceiling* /

PATRICK NORGUET / 2003

* canopy / rosone
white / bianco

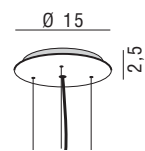

certifications / certificazioni



bulbs / lampadine

S | 4 x 40W G9 Clear Halogen
L | 4 x 48W G9 Clear Halogen

feeding / alimentazione

230 / 120 V

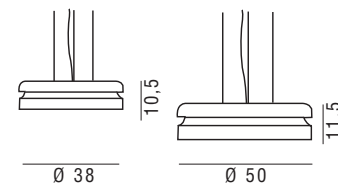

dimensions / dimensioni

S | Ø 38 cm - H 10,5 cm
L | Ø 50 cm - H 11,5 cm

finishing / finitura

gloss powder coated
verniciatura a polveri lucida

colours / colori



white/orange
white/black

Suspension lamp with direct light. Structure in white painted metal. Reflector in black/white or orange/white painted metal. Glass diffuser.

Lampada a sospensione a luce diretta. Struttura in metallo verniciato bianco. Riflettore in metallo verniciato bianco/arancio o bianco/nero. Diffusore in vetro.

Hängelampe mit direktem Licht. Weiss lackierte Metallstruktur. Reflektor in weiss-orangem oder weiss-schwarzem Metall. Glassdiffuser.

Lampe à suspension avec lumière directe. Structure en métal verni blanc. Réflecteur en métal verni blanc/orange ou blanc/noir. Diffuseur en verre.

Lámpara colgante de luz directa. Estructura de metal barnizado blanco. Reflector de metal barnizado blanco/naranja o blanco/negro. Difusor de vidrio.



SAMA ceiling /

GREGORIO SPINI / 2004

* canopy / rosone
white / bianco

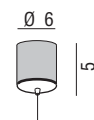

certifications / certificazioni

⊕ CE IP20

bulbs / lampadine

S | 1 x 50W GZ10
M | 1 x 50W GZ10

feeding / alimentazione

230 / 120 V

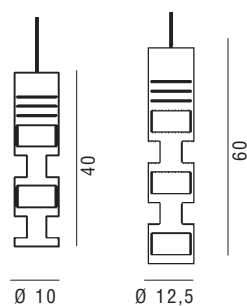

dimensions / dimensioni

S | Ø 10 cm - H 40 cm
L | Ø 12,5 cm - H 60 cm

finishing / finitura

gloss
lucida

colours / colori

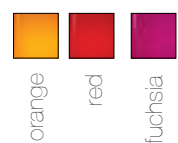

Ceiling spot light with a two tone co-extruded laser cut Plexiglas diffuser.

Lampada a sospensione a luce direzionale con diffusore in Plexiglas bicolore coestruso tagliato a laser.

Hängeleuchte mit Spotlicht aus einem zweifarbig coextrudierten, lasergeschnittenen Plexiglasdiffuser.

Lampe à suspension à lumière directionnelle avec un diffuseur en Plexiglas bicouleur co-extrudé coupé laser.

Lámpara colgante de luz direccional con difusor de Plexiglás bicolor co-extrudido cortado con láser.

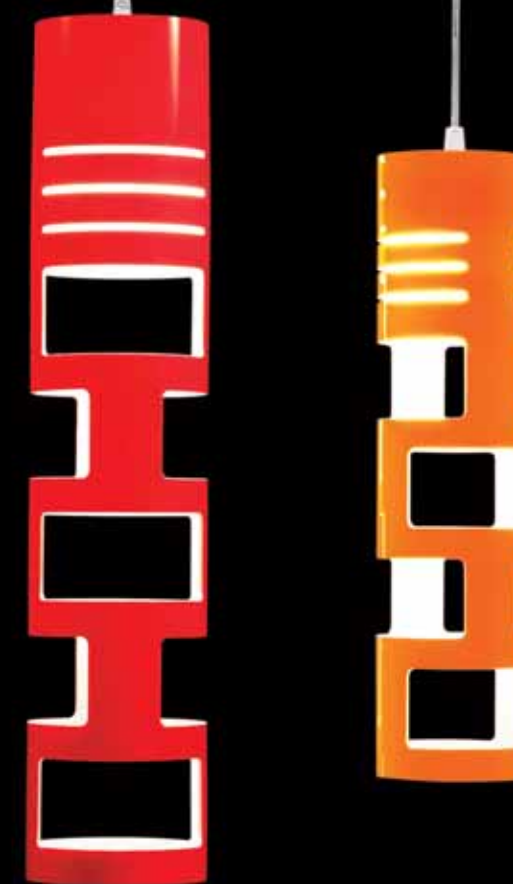

PIPE

JEAN MARIE MASSAUD / 2001



PIPE

JEAN MARIE MASSAUD / 2007

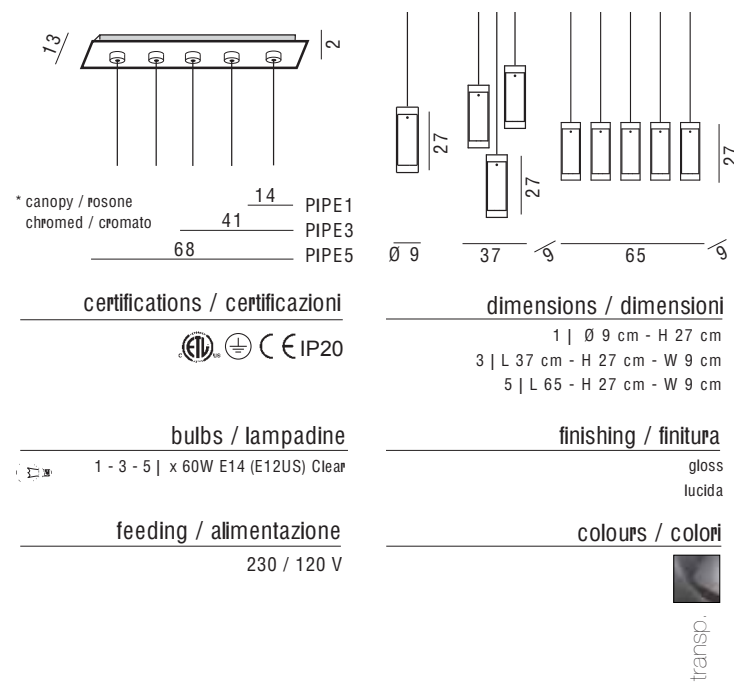

Suspension lamp height adjustable, structure in anodised aluminium. Diffuser in transparent glass with perforated aluminium screen.

Lampada a sospensione, struttura in alluminio anodizzato. Diffusore in vetro trasparente e schermo in alluminio microforato brillantato.

Hängeleuchte, eloxierte Aluminiumstruktur. Diffuser in durchsichtigem Glas mit fein durchlöcherter Aluminiumschirm.

Lampe à suspension, structure en aluminium anodisé. Diffuseur en verre transparent avec écran en aluminium micropercé.

Lámpara colgante, estructura de aluminio anodizado. Difusor de vidrio transparente y pantalla de aluminio microperforado enlucido.



PADMA *ceiling* /
MARZIO RUSCONI CLERICI / 2004

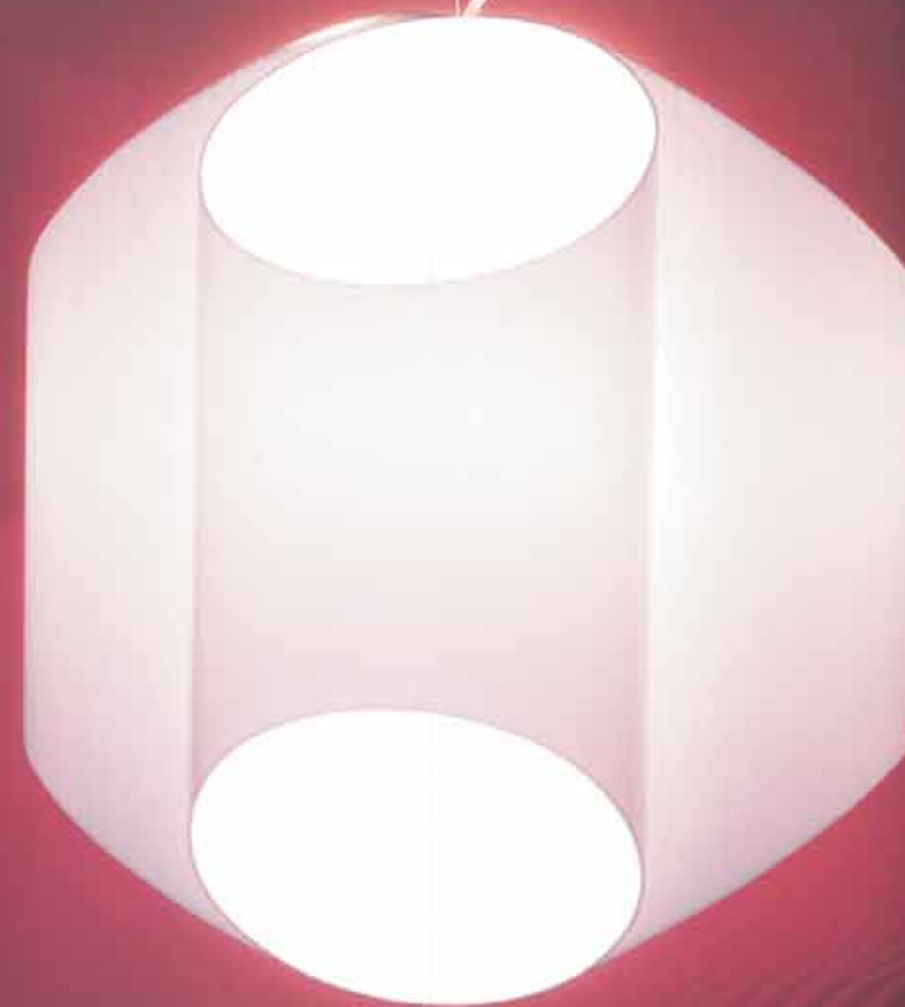

PADMA ceiling /

MARZIO RUSCONI CLERICI / 2004

* canopy / rosone
white / bianco

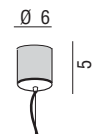

certifications / certificazioni

⊕ CE IP20

bulbs / lampadine

⊕ PADMA | 3 x 60W E14 (E12US)
Clear

⊕ PADMA L | 3 x 80W E27 (E26US)
Clear Tubular Halogen

feeding / alimentazione

230 / 120 V

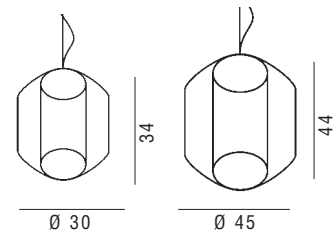

dimensions / dimensioni

PADMA S | Ø 30 cm - H 34 cm
PADMA L | Ø 45 cm - H 44 cm

finishing / finitura

gloss
lucida

colours / colori

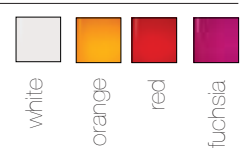

Ceiling lamp with three diffusers in white or two tone co-extruded laser cut Plexiglas and aluminium reflector.

Lampada a sospensione con tre diffusori in Plexiglas bianco o bicolore coestruso tagliato a laser e riflettore in alluminio.

Hängeleuchte aus drei lasergeschnittene, weiße oder zweifarbig coextrudierte Plexiglasdiffusers, mit Aluminium-reflektor.

Lampe à suspension avec trois diffuseurs en Plexiglas blanc ou bicolore co-extrudé coupé laser avec un réflecteur en aluminium.

Lámpara colgante con tres difusores de Plexiglás blanco o bicolor co-extrudido cortado con láser y reflector de aluminio.



E.T.A. SAT

GUGLIELMO BERCHICCI / 1997



E.T.A. SAT

GUGLIELMO BERCHICCI / 1997

* canopy / rosone
white / bianco

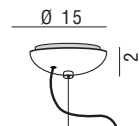

certifications / certificazioni

⊕ CE IP20

bulbs / lampadine

E.T.A. SAT | 1 x 60W E14 (E12US)
Clear Round Bulb

1 x 120W E27 (E26US)
Clear Tubular Halogen

E.T.A. SAT GIANT | 6 x 21W
E27 (E26US) Fluo

2 x 16W E27 (E26US) Fluo

feeding / alimentazione

230 / 120 V

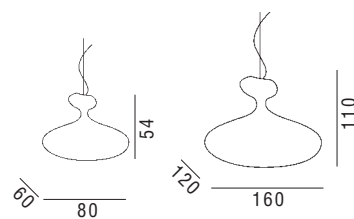

dimensions / dimensioni

E.T.A. SAT | L 80 cm - H 54 cm - W 60 cm
GIANT | L 160 cm - H 110 cm - W 120 cm

finishing / finitura

coloured fibreglass
vetroresina colorata

colours / colori

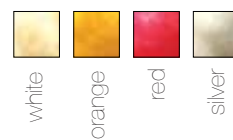

Suspension lamp. Handmade light diffuser in ecological fibreglass, with polycarbonate reflector, metallic inner structure.

Lampada a sospensione. Corpo diffusore in vetroresina ecologica fatto a mano, con riflettore in policarbonato, struttura interna in metallo.

Hängeleuchte. Handgemachter Diffusor aus ökologischem Fiberglas, mit Polykarbonatreflektor, interne metallene Leuchtmittelhalterung.

Lampe à suspension. Diffuseur en fibre de verre écologique fait à la main, avec réflecteur en polycarbonate, structure intérieure en métal.

Lámpara colgante. Cuerpo difusor de resina de vidrio ecológica trabajado a mano, reflector de policarbonato, estructura interna de metal.



TRIPOD *ceiling* /
CHRISTOPHE PILLET / 2002



TRIPOD *ceiling* /

CHRISTOPHE PILLET / 2002

* canopy / rosone
white / bianco
grey / grigio

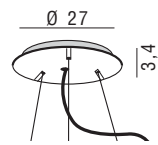

certifications / certificazioni

CE IP20

bulbs / lampadine

3 x 80W E27 (E26US)
Clear Tubular Halogen
OR 3 x 21W E27 (E26US) Fluor

feeding / alimentazione

230 / 120 V

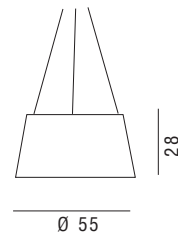

dimensions / dimensioni

Ø 55 cm - H 28 cm

finishing / finitura

fabric
tessuto

colours / colori

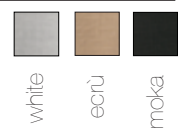

Suspension lamp, structure in grey or white painted metal. Shade in fire resistant fabric closed by an anodized perforated aluminium disc.

Lampada a sospensione, struttura in metallo verniciato grigio o bianco. Paralume in tessuto ignifugo chiuso da un disco in alluminio microforato e anodizzato.

Hängeleuchte, grau oder weiss lackierte Metallstruktur. Diffuser in feuerfestem Stoff, von durchlöcherter eloxierter Aluminiumscheibe verschlossen.

Lampe à suspension, structure en métal verni gris ou blanc. Diffuseur en tissu ignifuge fermé par un disc en aluminium micropercé anodisé.

Lámpara colgante, estructura de metal barnizado gris o blanco. Pantalla de tejido ignifugo fijada con disco de aluminio microperforado y anodizado.



FRAME
BENJAMIN HUBERT / 2011

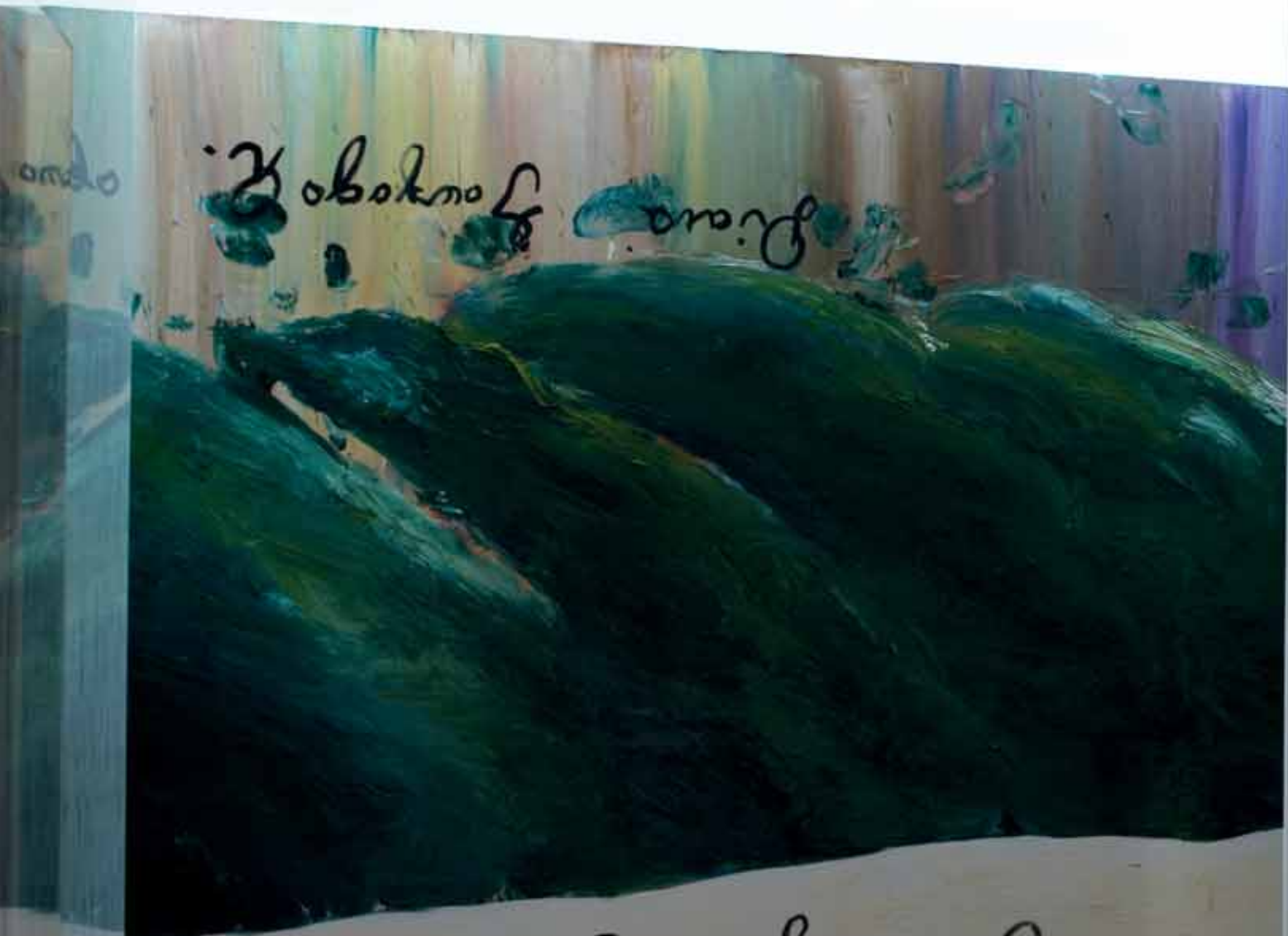

Diana Gonzalez R.



FRAME

BENJAMIN HUBERT / 2011

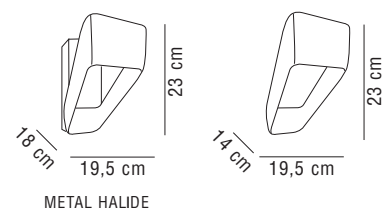

certifications / certificazioni

⊕ CE IP20

lampadine / bulbs

1 x max 150W R7S 78mm
METAL HALIDE | 1 x max 35W
G8.5

feeding / alimentazione

230 / 120 V

dimensions / dimensioni

L 19,5 cm - H 23 cm - 14 cm
METAL HALIDE | L 19,5 cm - H 23 cm - 18 cm

finishing / finitura

matt powder coated or chromed
verniciatura a polveri opaca o cromata

colours / colori

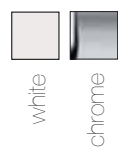

Wall lamp. Die-casted matt varnished or chromed aluminium diffuser. Metal halide version available.

Lampada da parete. Corpo in alluminio pressofuso verniciato opaco o cromato. Disponibile nella versione a ioduri metallici.

Wandleuchte. Körper aus Aluminiumdruckguss, matt lackiert oder verchromt. Version aus metallischen Jodiden verfügbar.

Applique. Corps en aluminium moulée vernis mat ou aluminium chromé. Version disponible métal halogène.

Applique. Estructura en aluminio de fundición pintado mate o cromado. Disponible en la versión de halogenuro metálico.



EVITA *wall* /
AQUILIALBERG / 2011



EVITA wall /
AQUILIALBERG / 2011

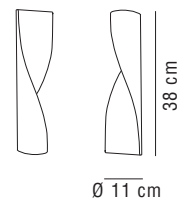

Wall lamp. Powder coated laser cut metal structure, opal methacrylate diffuser.

Lampada da parete. Struttura in metallo verniciato tagliato laser, diffusore in metacrilato opalino.

Wandleuchte. Lasergeschnittene lackierte Metallstruktur, Diffusor aus Methacrylat Opalin.

Applique. Structure en métal verni coupé laser, diffuseur en méthacrylate opalin.

Aplique. Estructura en metal lacado corte laser, difusor en metacrilato opal.

certifications / certificazioni

⊕ C E IP20

bulbs / lampadine

1 x 24W 2G11 Fluor

feeding / alimentazione

230 / 120 V

dimensions / dimensioni

Ø 11 cm - H 38 cm

finishing / finitura

gloss powder coated
verniciatura a polveri lucida

colours / colori

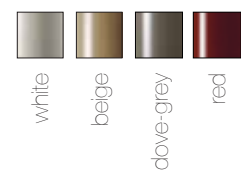

white

beige

dove-grey

red



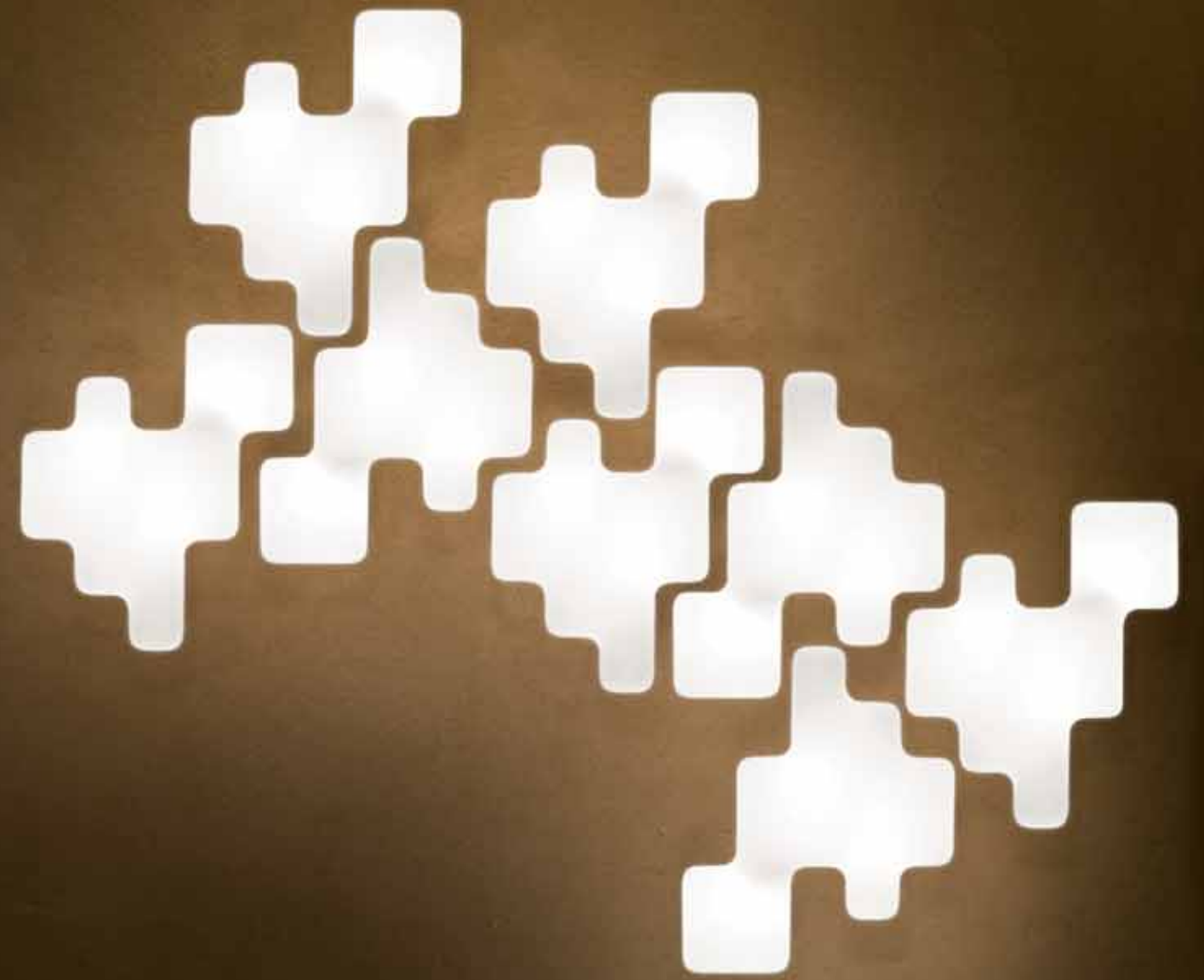

PIXEL

BAKERY GROUP / 2009

Wall and ceiling lamp. Roto-moulded polyethylene diffuser fixed to a varnished metal structure.

Lampada da parete e da soffitto. Diffusore in polietilene stampato in rotazionale, fissato a struttura portante in metallo verniciato.

Wand- und Deckenleuchte. Polyethylen diffuser Rotationsguß auf einer versteckten Metallhalterung.

Applique et plafonnier composée d'un diffuseur en polyéthylène imprimé en rotomoulage et d'une structure portante en métal verni.

Lámpara de pared y de techo. Difusor de polietileno estampado en rotacional, fijado a una estructura portante de metal barnizado.

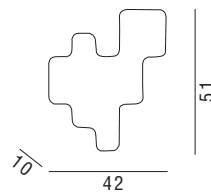

certifications / certificazioni

⊕ CE IP20

bulbs / lampadine

3 x 12W E14(E12US) Fluo

feeding / alimentazione

230 / 120 V

dimensions / dimensioni

L 42 cm - H 51 cm - W 10 cm

finishing / finitura

gloss
lucida

colours / colori



white



DOX

PAOLO CAZZARO / 2008



DOX
PAOLO CAZZARO / 2008



Indoor and outdoor wall lamp with diffusers in satin opal Plexiglas and varnished polyurethane body attached to metal structure.

Lampada a parete per interni ed esterni con diffusori in Plexiglas opale satinato e corpo in poliuretano verniciato, fissato a struttura portante in metallo.

Innen und aussen wandleuchte mit opalmatten Plexiglasdiffusers und lackiertem Polyurethankörper an Metallstruktur befestigt.

Applique pour l'intérieur et l'extérieur avec diffuseurs en Plexiglas opalin satiné et corps en polyuréthane coloré, fixé à une structure métallique.

Lámpara de pared para interiores y exteriores con difusores de Plexiglás ópalo satinado y cuerpo de poliuretano barnizado, fijado a una estructura portante de metal.

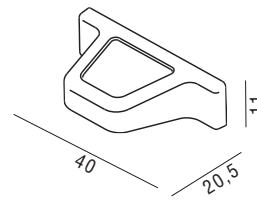

certifications / certificazioni

⊕ C E IP20 or IP44

dimensions / dimensioni

L 40 cm - H 11 cm - W 20,5 cm

bulbs / lampadine

2 x 16W E27(E26US) Fluor

finishing / finitura

matt liquid varnished
verniciatura a liquido opaca

feeding / alimentazione

230 / 120 V

colours / colori

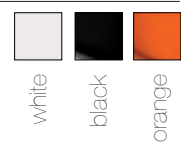

DOX L
PAOLO CAZZARO / 2008



DOX L

PAOLO CAZZARO / 2008

Indoor and outdoor wall lamp with diffusers in satin opal Plexiglas and varnished polyurethane body attached to metal structure.

Lampada a parete per interni ed esterni con diffusori in Plexiglas opale satinato e corpo in poliuretano verniciato, fissato a struttura portante in metallo.

Innen und aussen wandleuchte mit opalmatten Plexiglasdiffusers und lackiertem Polyurethankörper an Metallstruktur befestigt.

Applique pour l'intérieur et l'extérieur avec diffuseurs en Plexiglas opalin satiné et corps en polyuréthane coloré, fixé à une structure métallique.

Lámpara de pared para interiores y exteriores con difusores de Plexiglás ópalo satinado y cuerpo de poliuretano barnizado, fijado a una estructura portante de metal.

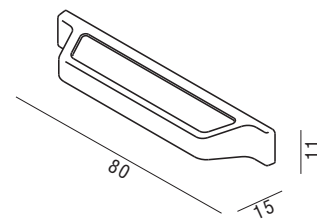

certifications / certificazioni

⊕ CE IP20 or IP44

bulbs / lampadine

1 x 55W 2G11 Fluor

feeding / alimentazione

230 / 120 V

dimensions / dimensioni

L 80 cm - H 11 cm - W 15 cm

finishing / finitura

matt liquid varnished
verniciatura a liquido opaca

colours / colori

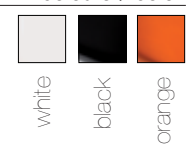

HEXAGON

L.LONGO & A.ROMANO - DE-SIGNUM / 2008



HEXAGON

L.LONGO & A.ROMANO - DE-SIGNUM / 2008

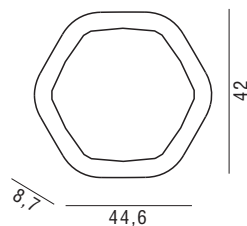

Wall and ceiling lamp with thermoformed diffuser in satin opal Plexiglas and colored frame.

Lampada da parete e da soffitto con diffusore termoformato in Plexiglas opale satinato e cornice colorata.

Wand- und Deckenleuchte aus thermogeforntem, opalmattem Plexiglasdiffuser und farbigem Rand.

Applique et plafonnier avec un diffuseur thermoformé en Plexiglas opalin satiné et encadrement coloré.

Lámpara de pared y de techo con difusor termoformado de Plexiglás ópalo satinado y marco de color.

certifications / certificazioni

⊕ CE IP20

dimensions / dimensioni

L 44,6 cm - H 42 cm - W 8,7 cm

bulbs / lampadine

1 x 40W T5 Fluor

finishing / finitura

opal diffuser + gloss coloured frame
diffusore opalino + cornice colorata lucida

feeding / alimentazione

230 V

colours / colori

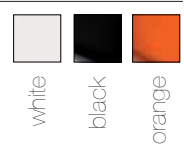

ATOMIUM *wall /*

HOPF&WORTMANN - BÜRO FÜR FORM / 2006

Wall and ceiling lamp with rotational-moulded polyethylene diffuser and inner structure with three light sources fixed on steel coil springs assembled on a laser-shaped coated base.

Lampada da parete e da soffitto con diffusore in polietilene stampato in rotazionale con struttura interna a tre luci montate su molle tensionate in acciaio, fissate su basamento sagomato a laser e verniciato.

Wandleuchte mit Polyethylen diffuser in Rotomoulding, innen Federstruktur aus Stahl mit drei Lampen, montiert auf Metallbasis.

Applique et plafonnier avec un diffuseur en polyéthylène imprimé en rotoroulage et une structure intérieure à trois luminaires placées sur des ressorts tensionnés en acier.

Lámpara de pared y de techo con difusor de polietileno estampado en rotacional con estructura interna de tres luces montadas sobre resortes tensados de acero, fijadas sobre una base perfilada con láser y barnizada.

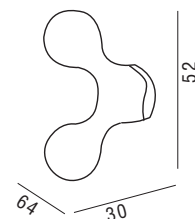

certifications / certificazioni

ETL, CE, IP20

dimensions / dimensioni

L 64 cm - H 52 cm - W 30 cm

bulbs / lampadine

3 x 40W E14 (E12US) Clear
OR 3 x 12W E14 (E12US) Fluo

finishing / finitura

gloss
lucida

feeding / alimentazione

230 / 120 V

colours / colori



white

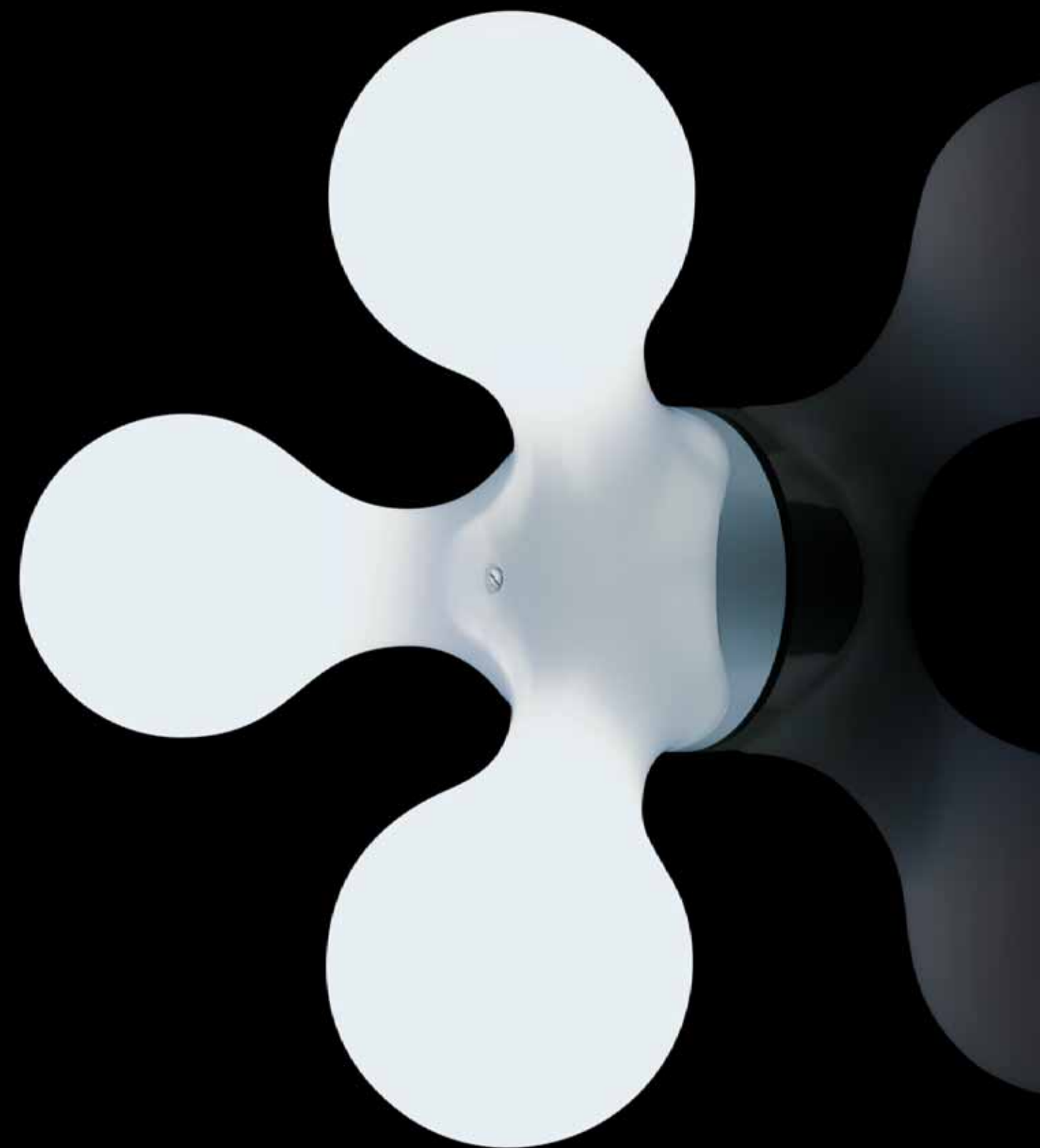

DROP

FUTURE SYSTEMS / 2006



DROP

FUTURE SYSTEMS / 2006

Wall and ceiling lamp with triplex opal glass diffuser, mouth blown and acid etched, fixed on a coated spun base.

Lampada da parete e da soffitto con diffusore in vetro opale incamiciato, soffiato e acidato, montato su fondello tornito e verniciato.

Wand- und Deckenleuchte aus mundgeblasenem und geätztem Triplexglasdiffuser, mit lackierter Metallstruktur.

Applique et plafonnier avec un diffuseur en verre opalin, acidé et soufflé triplex, monté sur une base repoussée et vernie.

Lámpara de pared y de techo con difusor de vidrio ópalo enfundado, soplado y acidado, montado sobre base torneada y barnizada.

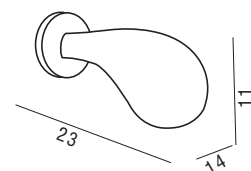

certifications / certificazioni

⊕ CE IP20

bulbs / lampadine

1 x 48W G9 Clear Halogen

feeding / alimentazione

230 / 120 V

dimensions / dimensioni

L 14 cm - H 11 cm - W 23 cm

finishing / finitura

acid etched glass
vetro acidato

colours / colori



white

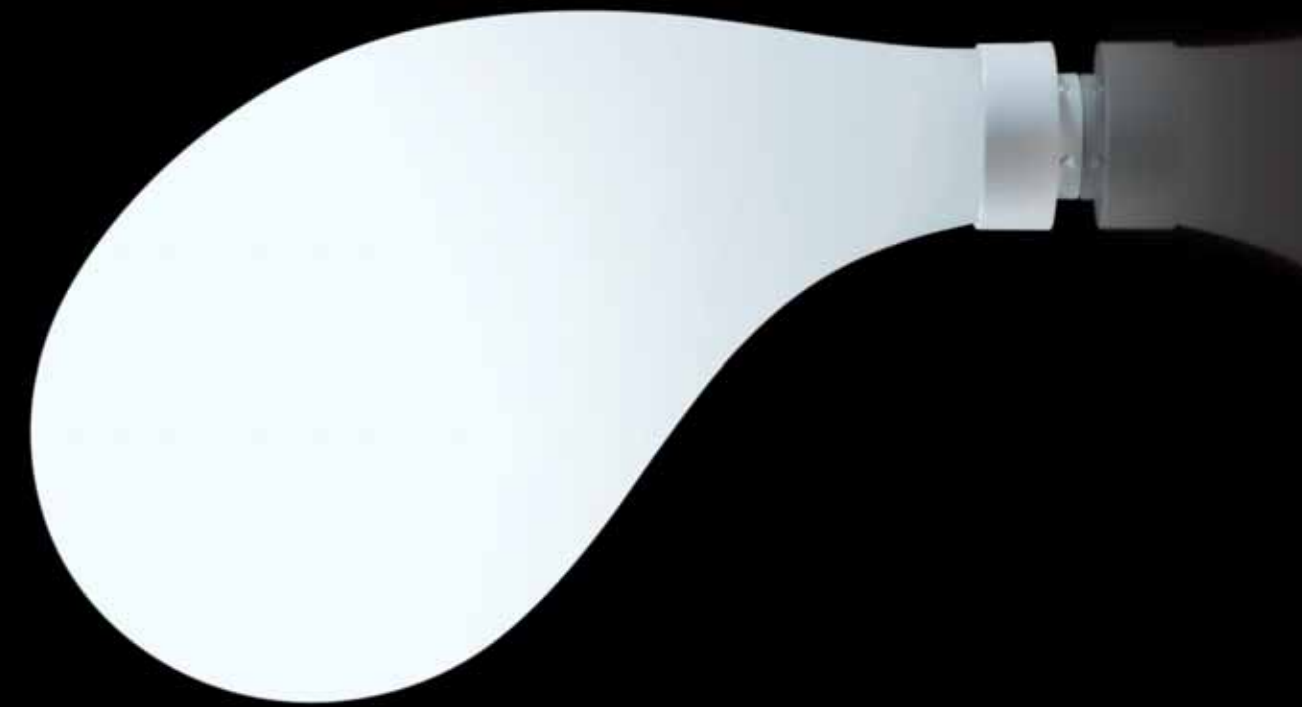

ALONE

GIORGIO GURIOLI / 2006

Wall and ceiling lamp with thermoformed diffuser in satin opal Plexiglas, fixed on two laser-cut and coated metal plates.

Lampada da parete e da soffitto con diffusore termoformato in plexiglas opale satinato, montato su doppia lastra di metallo tagliato al laser e verniciato.

Wand- und Deckenleuchte aus thermogeformtem, opalmattem Plexiglasdiffuser, montiert auf zwei lackierte Metallplatten.

Applique et plafonnier avec un diffuseur thermoformé en Plexiglas opalin satiné, monté sur une double plaque en métal coupé laser et vernis.

Lámpara de pared y de techo con difusor termoformado de plexiglás ópalo satinado, montado sobre una doble plancha de metal, cortado al láser y barnizado.

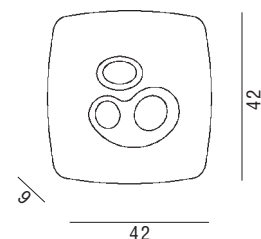

certifications / certificazioni

⊕ CE IP20

bulbs / lampadine

1 x 40W T5 Fluor

feeding / alimentazione

230 V

dimensions / dimensioni

L 42 cm - H 42 cm - W 9 cm

finishing / finitura

satin opal
opale satinata

colours / colori



white



MORPHIE

BRODIE NEILL / 2006



MORPHIE

BRODIE NEILL / 2006

Wall and ceiling lamp with two thermoformed diffusers in opal and transparent or transparently coloured Plexiglas, fixed on a metal coated structure with chrome-plated details.

Lampada da parete e da soffitto con due diffusori termoformati in Plexiglas opale e trasparente o trasparente colorato, montati su struttura metallica verniciata con particolari cromati.

Wand- und Deckenleuchte aus zwei thermogeformten Plexiglasdiffuser, opal und transparent oder farbig transparent, Wandhalterung aus Metall, sichtbare Befestigungselemente verchromt.

Applique et plafonnier avec deux diffuseurs thermoformés en Plexiglas opalin et transparent ou bien en couleurs transparents, fixés sur une structure en métal vernie avec des détails chromés.

Lámpara de pared y de techo con dos difusores termoformados de Plexiglas ópalo y transparente o transparente de color, montados sobre estructura metálica barnizada con detalles cromados.

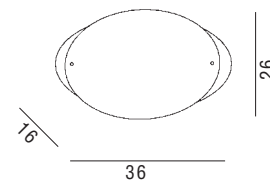

certifications / certificazioni

⊕ CE IP20

bulbs / lampadine

1 x 80W E27 (E26US)
Clear Tubular Halogen
OR 1 x 16W E27 (E26US) Fluor

feeding / alimentazione

230 / 120 V

dimensions / dimensioni

L 36 cm - H 26 cm - W 16 cm

finishing / finitura

gloss
lucida

colours / colori

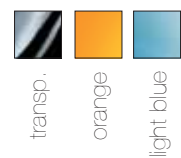

SHAKTI wall /
MARZIO RUSCONI CLERICI / 2002

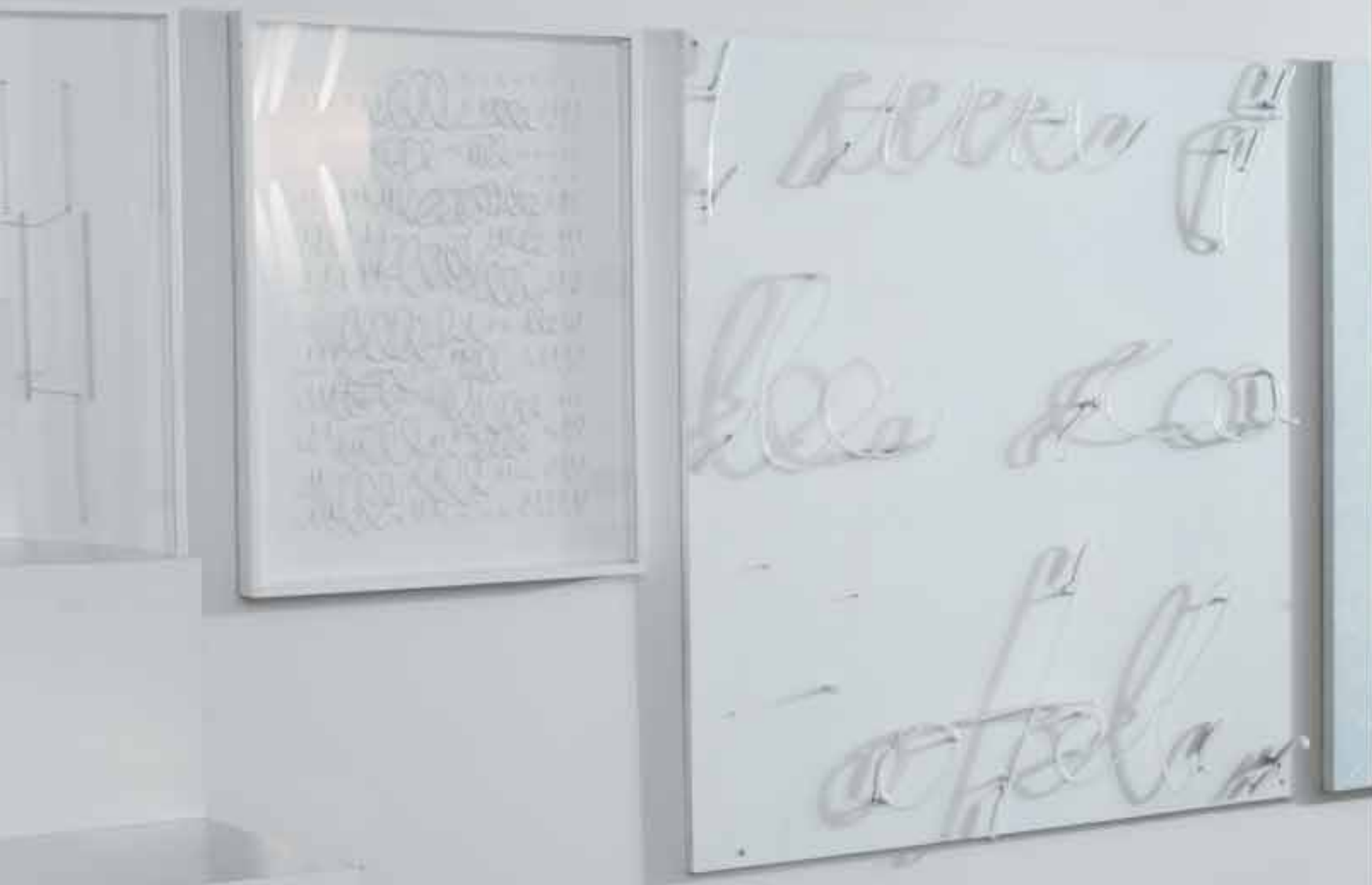

SHAKTI wall /

MARZIO RUSCONI CLERICI / 2002

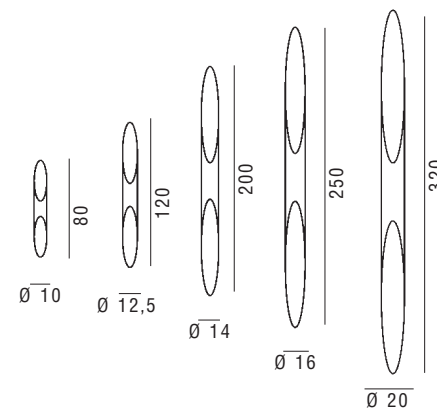





certifications / certificazioni



dimensions / dimensioni

FIX 80 | Ø 10 cm - H 80 cm
 FIX 120 | Ø 12,5 cm - H 120 cm
 WALL/FIX 200 | Ø 14 cm - H 200 cm
 WALL/FIX 250 | Ø 16 cm - H 250 cm
 WALL/FIX 320 | Ø 20 cm - H 320 cm

bulbs / lampadine

- 
 FIX 80 | 1 x 60W E27 (E26US)
 Clear Round
 OR 1 x 7W E27 (E26US) Fluo
- 
 FIX 120 | 1 x 80W E27 (E26US)
 Clear Tubular Halogen
 OR 1 x 11W E27 (E26US) Fluo
- 
 WALL/FIX 200 | 2 x 80W E27 (E26US)
 Clear Tubular Halogen
 OR 2 x 21W E27 (E26US) Fluo
- 
 WALL/FIX 250 | 2 x 120W E27 (E26US)
 Clear Tubular Halogen
 OR 2 x 25W E27 (E26US) Fluo
- 
 WALL/FIX 320 | 2 x 120W E27 (E26US)
 Clear Tubular Halogen
 OR 2 x 25W E27 (E26US) Fluo

finishing / finitura

gloss
 lucida

feeding / alimentazione

230 / 120 V

colours / colori

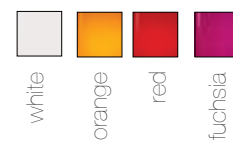

Double light wall lamp with tubular light diffuser laser cut in Plexiglas. Available for direct wall mounting or with cable, plug and dimmer.

Lampada a parete a due luci con diffusore tubolare in Plexiglas tagliato a laser. Shakti Wall è disponibile nella versione per punto luce o nella versione con spina e dimmer.

Wandleuchte mit doppelter Lichtquelle in einem laser-geschnittenen Plexiglasdiffuser. Lieferbar in der Version für elektrischer Wandanschluss, oder verkabelt mit Stecker.

Applique à deux lumières avec le diffuseur tubulaire en Plexiglas coupé laser. Shakti Wall est disponible dans la version traditionnelle et en la version avec une fiche et un gradateur de lumière.

Lámpara de pared con dos luces con difusor tubular de Plexiglas cortado con láser. Shakti Wall está disponible en la versión para punto luz o en la versión con enchufe y dimmer.

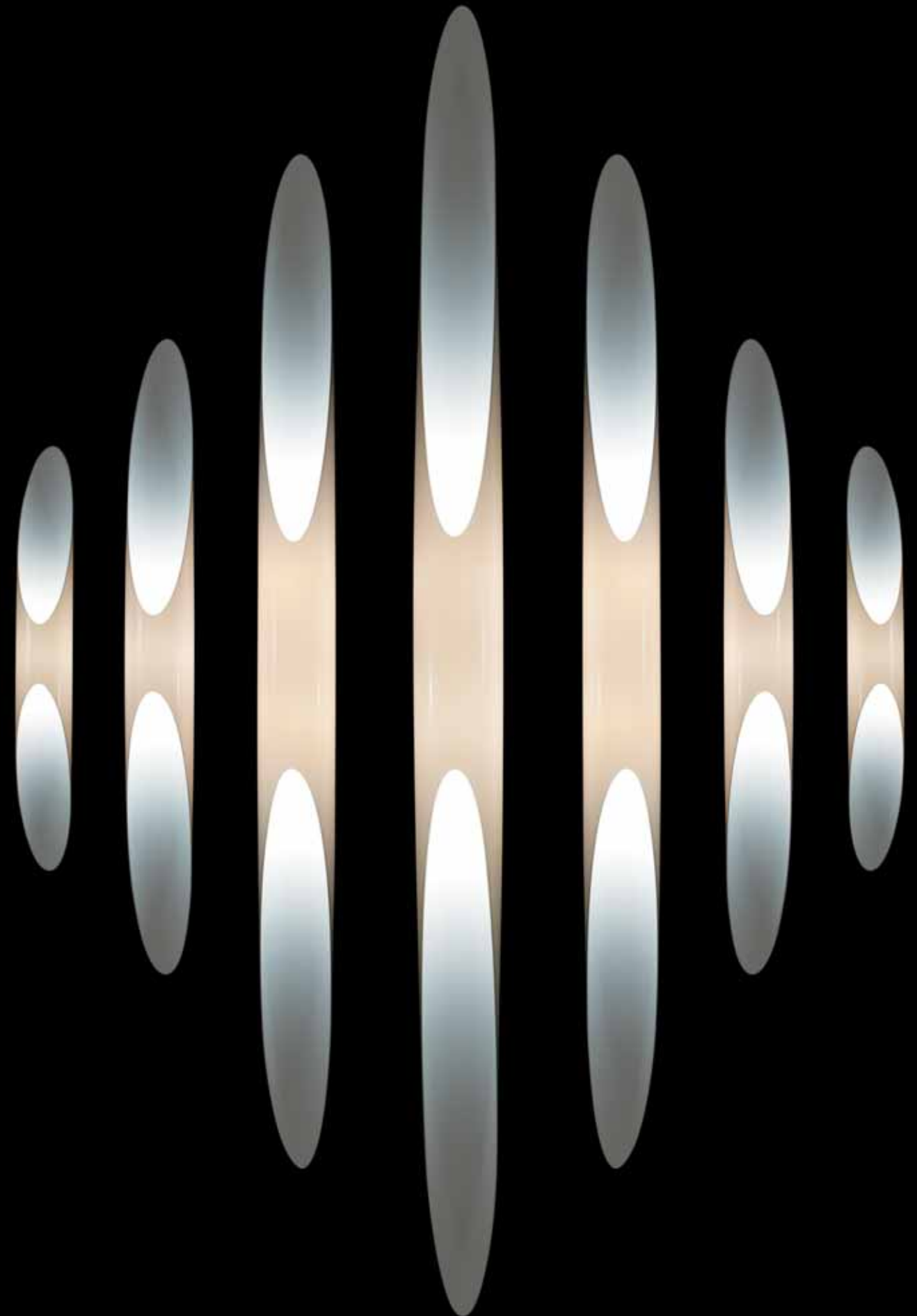

FLAP

JEAN MARIE MASSAUD / 2000



FLAP

JEAN MARIE MASSAUD / 2000

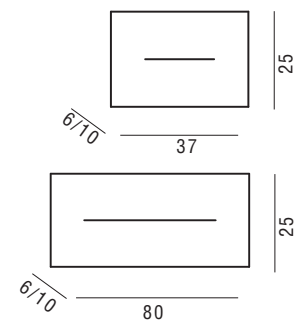

Adjustable wall lamp indirect light, structure in white painted metal. White or grey metal reflector.

Lampada da parete orientabile a luce indiretta, struttura in metallo verniciato bianco. Riflettore in metallo verniciato grigio o bianco.

Regulierbare Wandlampe mit indirektem Licht, weiss lackierte Metallstruktur. Reflektor in grau oder weiss lackiertem Metall.

Applique réglable avec lumière indirect, structure en métal verni blanc. Réflecteur en métal verni gris ou blanc.

Lámpara de pared orientable de luz indirecta, estructura de metal barnizado blanco. Reflector de metal barnizado gris o blanco.

certifications / certificazioni

⊕ CE IP20

bulbs / lampadine

S | 1 x 30W E27 (E26US) Fluor
L | 1 x 80W 2G11 Fluor

feeding / alimentazione

230 / 120 V

dimensions / dimensioni

S | L 37 cm - H 25 cm - W 6/10 cm
L | L 80 cm - H 25 cm - W 6/10 cm

finishing / finitura

matt powder coated
verniciatura a polveri opaca

colours / colori



white

grey

MANDALA

ALESSANDRO MENDINI / 2006



MANDALA

ALESSANDRO MENDINI / 2006

Wall and ceiling lamp with curved plated glass diffuser pressed with "fracco" and hand-decorated. Spun and chrome-plated metal frame fixed on a coated box structure.

Lampada da parete e da soffitto con diffusore in vetro in piastra curvato, lavorato al fracco e decorato a mano. Sostegni in metallo tornito e cromato fissati su struttura inscatolata verniciata.

Wand- und Deckenleuchte aus gegossenem, auf "fracco" gedrucktem Glas, handbemalt. Sichtbare Befestigungen aus verchromtem Metall.

Applique et plafonnier avec un diffuseur en verre coulé et courbé, imprimé au "fracco" et décoré à la main. Soutiens en métal repoussé et chromé montés sur une structure à boîte vernie.

Lámpara de pared y de techo con difusor de vidrio en plancha curvado, trabajado con un especial aparato artesanal (fracco) y decorado a mano. Soportes de metal torneado y cromado, fijados sobre una estructura en caja barnizada.

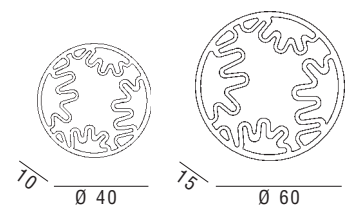

certifications / certificazioni

⊕ CE IP20

dimensions / dimensioni

S | Ø 40 cm - W 10 cm
L | Ø 60 cm - W 15 cm

bulbs / lampadine

S | 2 x 80W R7S 118mm
L | 2 x 80W R7S 118mm

feeding / alimentazione

230 / 120 V

finishing / finitura

gloss
lucida

colours / colori



coloured

silver



MANDALA

KARIM RASHID / 2006



MANDALA

KARIM RASHID / 2006

Wall and ceiling lamp with curved plated glass diffuser pressed with "fracco" and hand-decorated. Spun and chrome-plated metal frame fixed on a coated box structure.

Lampada da parete e da soffitto con diffusore in vetro in piastra curvato, lavorato al fracco e decorato a mano. Sostegni in metallo tornito e cromato fissati su struttura inscatolata verniciata.

Wand- und Deckenleuchte aus gegossenem, auf "fracco" gedrucktem Glas, handbemalt. Sichtbare Befestigungen aus verchromtem Metall.

Applique et plafonnier avec un diffuseur en verre coulé et courbé, imprimé au "fracco" et décoré à la main. Soutiens en métal repoussé et chromé montés sur une structure à boîte vernie.

Lámpara de pared y de techo con difusor de vidrio en plancha, trabajado con un especial aparato artesanal (fracco) y decorado a mano. Soportes de metal torneado y cromado, fijados sobre una estructura en caja barnizada.

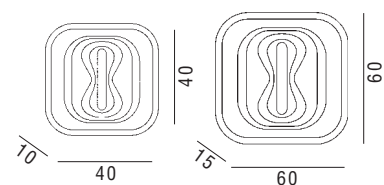

certifications / certificazioni

⊕ CE IP20

dimensions / dimensioni

S | Ø 40 cm - W 10 cm
L | Ø 60 cm - W 15 cm

bulbs / lampadine

S | 2 x 80W R7S 118mm
L | 2 x 80W R7S 118mm

finishing / finitura

gloss
lucida

feeding / alimentazione

230 / 120 V

colours / colori

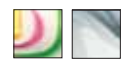

coloured
silver



PASTILLA

PATRICIA URQUIOLA / 2000



PASTILLA

PATRICIA URQUIOLA / 2000

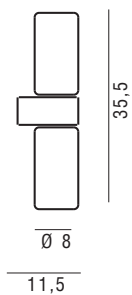

Wall lamp, structure in white painted metal. Diffuser in pressed acid etched glass.

Lampada da parete, struttura in metallo verniciato bianco. Diffusore in vetro pressato e acidato.

Wandleuchte, weiss lackierte Metallstruktur. Diffuser in gepresstem und geätztem Glas.

Applique, structure en métal verni blanc. Diffuseur en verre pressé et acidé.

Lámpara de pared, estructura de metal barnizado blanco. Difusor de vidrio prensado y acidado.

certifications / certificazioni

⊕ CE IP10

bulbs / lampadine

2 x 60W E14 (E12US) Clear

feeding / alimentazione

230 / 120 V

dimensions / dimensioni

Ø 8 cm - H 35,5 cm - W 11,5 cm

finishing / finitura

acid etched glass + painted metal
vetro acidato + metallo verniciato

colours / colori



white/glass



PLUTO *wall /*

PAOLA NAVONE / 2006

Wall and ceiling lamp with mouth-blown diffuser, rotationally-formed and internally sand-blasted. This artistic craftwork makes unique any and each product. This irregularly shaped glass is assembled on chrome-plated metal fixtures through an harmonic steel crown spring. The diffuser is orientable at 360°.

Lampada da parete e da soffitto con diffusore in vetro soffiato, lavorato in rotazione e internamente sabbato. Questa lavorazione artistica rende unico ogni singolo prodotto. Il vetro dalla forma irregolare è fissato a sostegni metallici cromati tramite una molla di acciaio armonico a corona. Il diffusore è posizionabile a piacere a 360°.

Wand- und Deckenleuchte aus mundgeblasenem Glasdiffuser, in Rotation handverarbeitet, innen satiniert. Diese Fertigung macht jedes Glas einzigartig. Verchromte Metallstruktur mit innenliegender Stahlfeder.

Applique et plafonnier avec un diffuseur en verre soufflé, ouvert en rotation e internement sablé. Cet ouvrage artistique rend unique chaque produit. Le verre, dont la forme est irrégulière, est fixé à des détails en métal chromé à travers un ressort à couronne en acier harmonique. Le diffuseur peut être tourné à plaisir à 360°.

Lámpara de pared y de techo con difusor de vidrio soplado, trabajado en rotación y arenado en su interior. Esta elaboración artística hace que cada pieza sea única. El vidrio de forma irregular está fijado a soportes de metal cromado mediante un resorte de corona de acero armónico. El difusor se puede orientar a gusto a 360°.

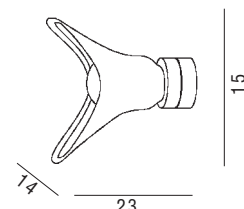

certifications / certificazioni

⊕ CE IP20

bulbs / lampadine

1 x 40W G9 Clear Halogen

feeding / alimentazione

230 / 120 V

dimensions / dimensioni

L 14 cm - H 15 cm - W 23 cm

finishing / finitura

gloss
lucida

colours / colori



transp.



E-TURN

BRODIE NEILL / 2007



E-TURN

BRODIE NEILL / 2007

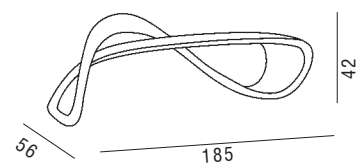

finishing / finitura
lacquered
laccata

dimensions / dimensioni
L 185 cm - H 42 cm - W 56 cm

colours / colori

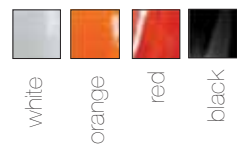

Handmade sculptural bench in lacquered fibreglass.

Panca scultorea interamente realizzata a mano in vetroresina laccata.

Handverarbeitete skulpturale Bank aus lackiertem Fiberglas.

Banque sculptural entièrement réalisé à la main en fibre de verre laquée.

Banco escultural completamente realizado a mano en resina de vidrio lacado.

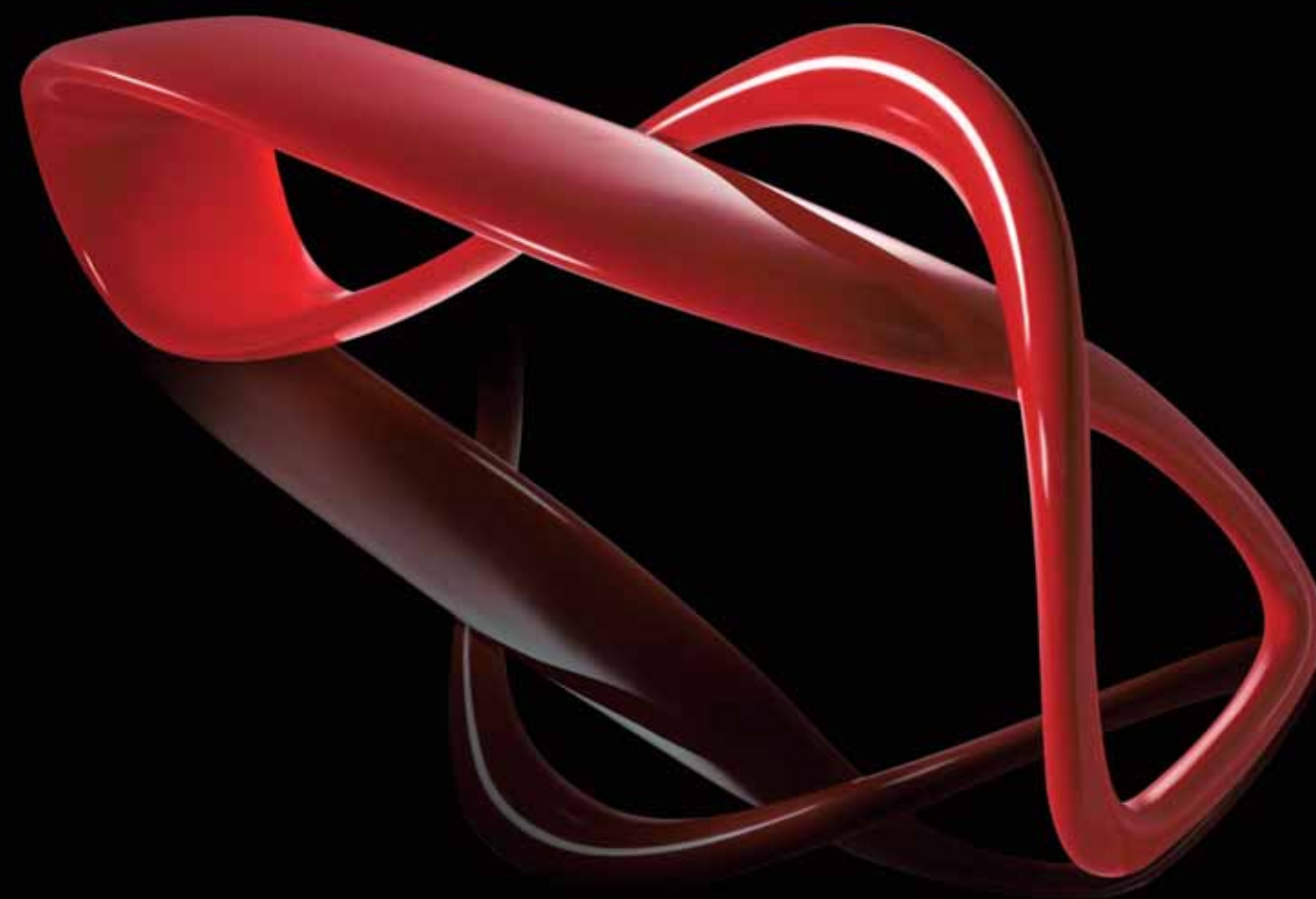

HARA
GIORGIO GURIOLI / 2002



HARA

GIORGIO GURIOLI / 2002

Hara is a bio-energetic seat handmade in lacquered fibreglass. Ideal for outdoors thanks to a treatment against ultra-violet rays and to the strong resistance of the material to temperature changes.

Hara è una seduta bioenergetica in vetroresina laccata interamente realizzata a mano. Ideale anche per esterni grazie alla protezione dai raggi UV e alla grande resistenza del materiale all'escursione termica.

Hara ist ein bioenergetischer Sessel in lackiertem Fiberglas, ganzheitlich handgefertigt. Hara ist im Außenbereich auch ideell, dank dem UV Schutz und der großen Resistenz des Materials auf thermischer Exkursion.

Hara est un siège bioénergétique en fibre de verre laquée entièrement réalisée à la main. Il est aussi idéal pour l'extérieur grâce à la protection aux rayons UV et à la grande résistance du matériel à l'amplitude thermique.

Hara es un asiento bioenergético de resina de vidrio, lacado, realizado completamente a mano. Ideal también para exteriores gracias a la protección contra los rayos UV y a la gran resistencia del material a la excursión térmica.

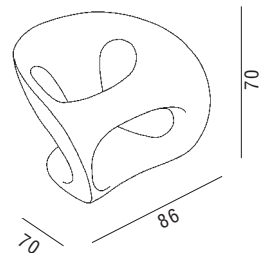

dimensions / dimensioni
L 86 cm - H 70 cm - W 70 cm

colours / colori

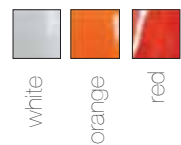

finishing / finitura
lacquered
laccata



/ marking /



This mark guarantees that the product has passed all the tests established for electrical safety standards by the European Community. EN 60598-1 regulations corresponding to Italian norms for electric security CEI 34-24.

La marcatura indica che il prodotto ha superato positivamente tutte le prove previste dalle normative per la sicurezza elettrica, richieste dalla Comunità Europea. Normative EN 60598-1 corrispondenti alle norme Italiane per la sicurezza elettrica CEI 34-24.



Specific regulation for USA and Canada market.
Normativa specifica per il mercato Stati Uniti Canada

IP10

Device protected against penetration of solid bodies over 50 mm of diameter.
Apparecchio a prova di penetrazione di corpi solidi di dimensioni superiori a 50 mm di diametro.

IP20

Device protected against penetration of solid bodies over 12 mm of diameter.
Apparecchio a prova di penetrazione di corpi solidi di dimensioni superiori a 12 mm di diametro.

IP44

Device protected against penetration of solid bodies of 1 mm of diameter and protected against splashing water.
Apparecchio a prova di penetrazione di corpi solidi di 1 mm di diametro e protetto contro gli spruzzi.

IP65

Device dust-tight and protected against splashing water.
Apparecchio totalmente protetto contro la polvere e protetto contro gli spruzzi d'acqua.



Class 1. Single isolation: protective grounding is required.
Classe 1. Isolamento semplice: è richiesta la messa a terra di protezione.



Class 2. Double isolation: protective grounding is not required.
Classe 2. Doppio isolamento: non necessita di messa a terra di protezione.

/ notes /

* Suspension lamps are supplied with 1.8 meters long cables. Possible different lengths can be produced on demand.

Le lampade a sospensione sono dotate di cavi lunghi 1.8 metri. Eventuali misure diverse possono essere prodotte su richiesta.

* Product colors can differ from what is shown in the catalogue.

I colori dei prodotti possono variare rispetto a quanto rappresentato nel catalogo.

* All dimensions are in centimeters.

Tutte le misure sono espresse in centimetri.

* Bulbs are not included.

Le lampadine non sono incluse.

KUNDALINI SRL
I-20141 Milano
Via F. de Sanctis, 34
phone +39 02 3653 8950
fax +39 02 3653 8964
www.kundalini.it
info@kundalini.it

Printed in Italy
June 2011

KUNDALINI
IS A REGISTERED
TRADEMARK
all right reserved

 **KUNDALINI**

